



AUTOMATIC POLYPROPYLENE **STRAPPING MACHINE**

TP-6000-1 TP-6000-3

TP-6000CE1 TP-6000CE3

OPERATION MANUAL & SPARE PARTS LIST

**IMPORTANT!
KEEP IT WELL**

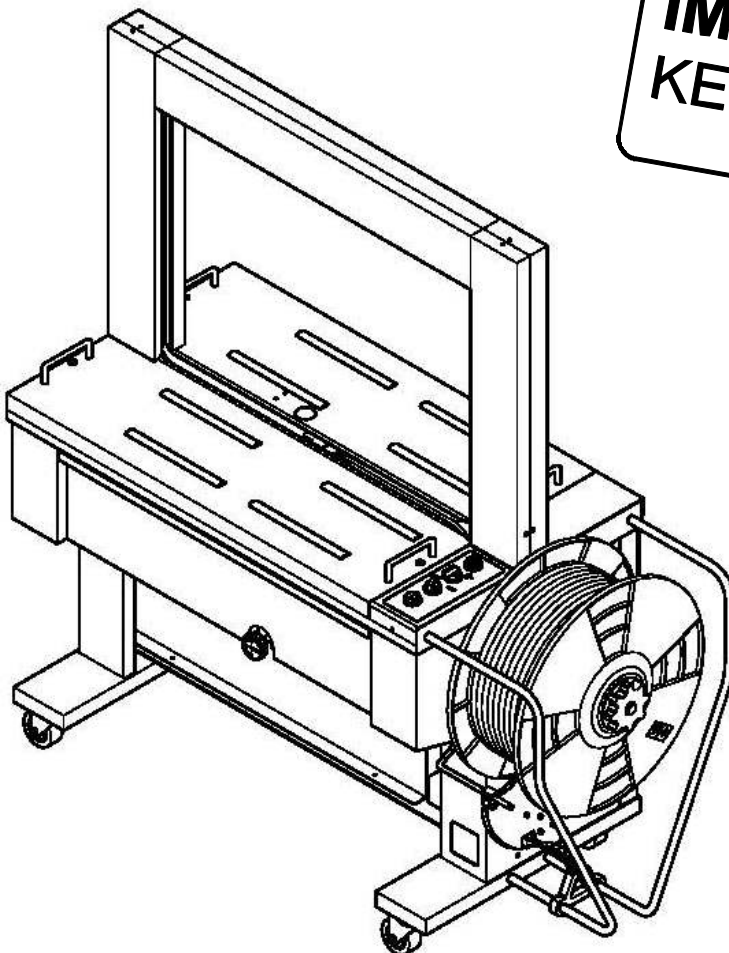

Original Instruction

READ ALL INSTRUCTIONS BEFORE OPERATING THIS PRODUCT

Explanations for Each Model NO. :

TP-6000-1 : Single Phase Model

TP-6000-3 : Three Phase Model

TP-6000CE1 : Single Phase With CE Version

TP-6000CE3 : Three Phase With CE Version

PART I

CONTENTS

1. Safety Instructions.....	1
(1) Before Operating	1
(2) During operating.....	1
(3) After operating.....	1
(4) Signs	1
(5) Maintenance	2
(6) Storage.....	2
(7) Other Reminders.....	2
2. Construction and Function of Units	3
3. General Safety Remarks.....	4
(1) Basic Operation	4
(2) Basic Safety Precautions	4
(3) Safety Instructions Governing Specific Operational Phases	4
(4) Warning of Electrical Dangers.....	5
(5) Grounding Instructions Shall Include the Following.....	6
4. Machine Information.....	7
(1) Areas of Application and Machine Description.....	7

(2) Technical Data	8
(3) Control Panel	9
(4) Electric Control Unit	11
5. Operating the Machine	13
(1) Operation Space.....	13
(2) Installation of Arch Unit.....	14
(3) How to Load P.P. Strap	16
6. Adjustments	18
(1) Tension strength	18
(2) Heater temperature	18
(3) Feed and take-up mechanism	19
(4) How to adjust LS3, LS2, LS1 (Movements of control unit)	20
(5) Amount of strap in Accumulator Box	21
7. Maintenance	22
8. How to Safely move the Machine	23
9. Troubleshooting	24
10. Wiring Diagram	26

1. Safety Instructions

(1) Before Operating

- a. Read the instruction manual.
- b. Wear eye protection and safety gloves before operating this machine.

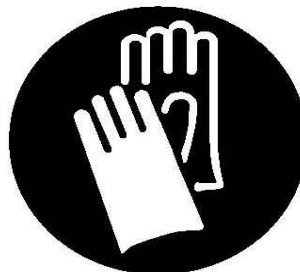
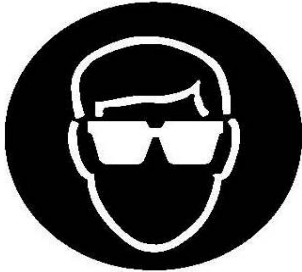

Eye protection must be worn Safety gloves must be worn Ear-protector must be worn

- c. Verify that the power line voltage is correct.
- d. The machine must be properly grounded to avoid a shock hazard. All wiring must be in accordance with local wiring standards.
- e. The strapping machine can only be operated with polypropylene (P.P.) strapping; do not use polyester (PET) strapping or polyethylene (PE) cord strap.

(2) During operating

- a. The weight of the package cannot exceed 100 kg (220 lbs),
- b. The size of the package should not be less than 100mm (width) × 20mm (high) (3.95” × 0.79”).
- c. Check if the machine emits any smokes or unusual sound when it is running.
- d. Keep away from the inside of the arch while the machine is operating; do not put your hands or body into the arch when the machine is running.

(3) After operating

- a. Remove dust and dirt from the unit; pay particular attention to the interior of the arch.
- b. Turn off the power when the machine is not in use.

(4) Signs

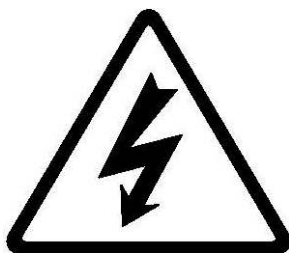

Caution, risk of electric shock



Do not touch!

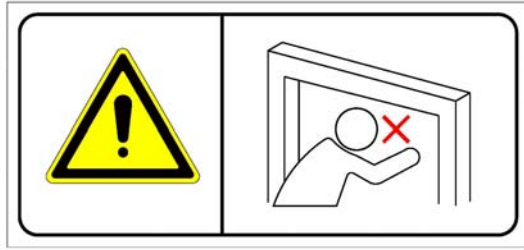

Warning for danger!
Do not put your hands or body into arch working area when machine is operating.

(5) Maintenance

- a. Turn off the power before removing either of the top covers.
- b. The heater tongue is very hot; do not touch it.

(6) Storage

- a. The store room must be dry.
- b. Do not expose the machine to extreme cold or heat environment.
- c. Place the machine on an even floor in order to avoid any distortion.

(7) Other Reminders

- a. An operation manual must remain attached to the machine at all times.
- b. Do not alter the equipment or circuitry unless authorized to do so by the manufacturer.
- c. Carry machine from the pallet with a forklift. The fork have to be under the machine frame.

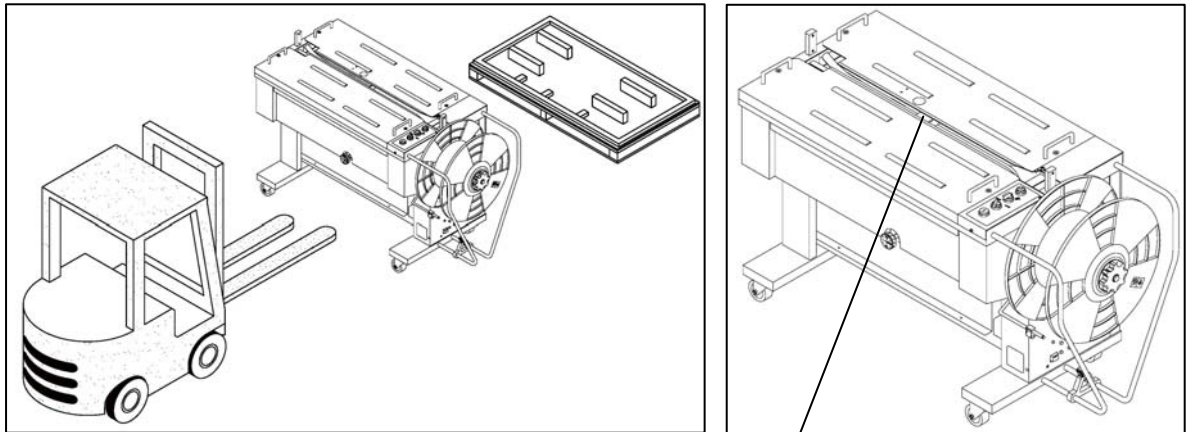

Center-of-gravity Position

2. Construction and Function of Units

1 Strapping head unit

This unit is the most important part of the machine for cutting and sealing of P.P. strap.

2 Bandway unit

This is the arch track through which P.P. strap forwards or reverses.

5 Body frame unit

Feeding and reversing of strap.

4 Reel unit

Holds the strap coil.
(If strap core is 280mm, you can take off the center drum to have core size 200mm.)

6 Electric control unit

3 Accumulator unit

This unit accumulates the quantity of strap required for smooth feeding into the arch track.

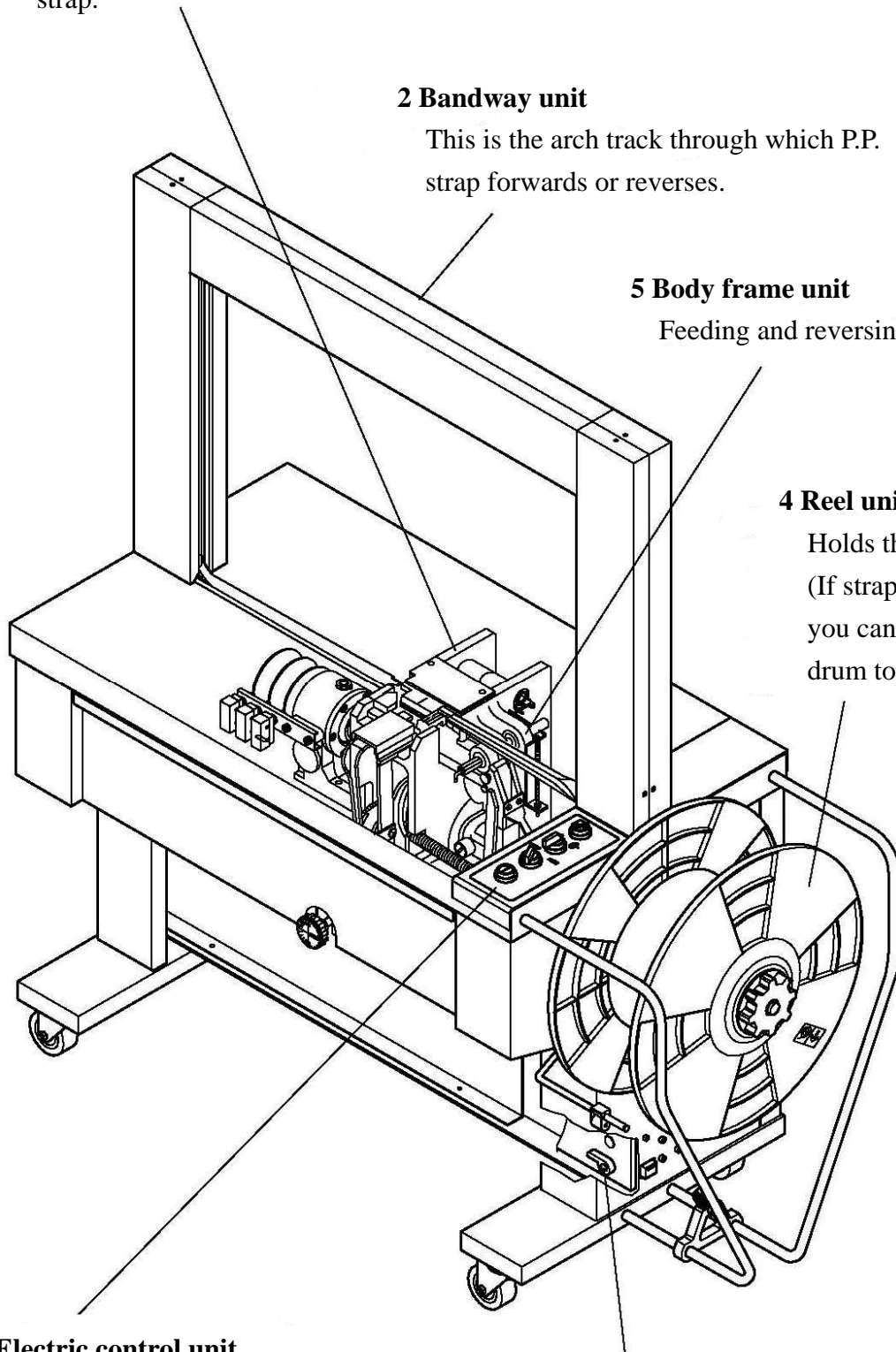

3. General Safety Remarks

(1) Basic Operation

The machine is only to be operated when in good running condition and in accordance with the instructions provided in the operation manual. Operators must be trained in proper operation and safety of the equipment.

The machine may only be operated in accordance with its designated use.

(2) Basic Safety Precautions

In addition to the instructions for operation, the user is to be instructed in all generally applicable legal or mandatory regulations relevant to safety or the environment.

Long hair, loose-fitting garments, or jewelry can be a safety hazard. These items must be secured prior to equipment operation.

Use protective equipment whenever appropriate or when required by law.

Carefully observe all safety instructions and warnings attached to the machine. Keep safety labels clean and legible.

People that are being trained to operate or service the equipment must be supervised by experienced personnel.

Any electrical work performed on the equipment must be conducted by a skilled electrician or under the supervision of a skilled electrician. All work must observe good electrical engineering practice and follow safety rules and local wiring standards.

(3) Safety Instructions Governing Specific Operational Phases

Avoid unsafe operation of the equipment.

The machine is only to be operated when it is in good running order. Only operate the equipment in a safe manner; all protective and safety devices must be in place and fully functional. This includes removable safety devices, emergency shut-off equipment, noise-protection devices and exhaust fans.

The machine is to be checked for damage and defects at least once each work shift. Any changes, including the working behavior of the machine, are to be reported immediately. If necessary, the machine is to be stopped and locked-out immediately.

In case of a malfunction, the strapping machine is to be immediately stopped and locked-out until the fault has been eliminated.

Before starting the strapping machine, make sure that the area is clear and safe.

Operating personnel need to be briefed before executing special operations and maintenance work; this work needs to be done with the proper supervision.

Always check and tighten connections after maintenance or repair.

After completing maintenance or repair, all safety devices must be replaced and checked for functionality before operating the equipment.

To minimize the environmental impact, all consumables and replaced parts must be disposed of safely.

Before starting the machine, check that the accessories have been stowed away safely.

Avoid operating the machine in a fashion that could upset its stability.

(4) Warning of Electrical Dangers

Electrical Energy

Immediately remove power to the machine in case of trouble in the electrical system. Replace a fuse with one with the same style and ratings; pay particular attention to matching the specified current.

Any electrical work performed on the equipment must be conducted by a skilled electrician or under the supervision of a skilled electrician. All work must observe good electrical engineering practice and follow safety rules and local wiring standards.

Inspect the electrical equipment of the machine at regular intervals. Tighten any loose connections. Check wiring for scorch marks; replace scorched wiring and determine and correct the reason for the overheating.

When working on live equipment, ensure that a second person is available to cut power in case of an emergency. When appropriate, secure the working area with safety tape and a warning sign. Use insulated tools for electrical work.

Before working on high-voltage assemblies, turn off the power supply. Carefully discharge the supply cable and short-circuit any energy-storage components such as capacitors.

If the equipment was moved, carefully refit and refasten all parts removed for transport before reapplying power.

Before moving the machine, remember to disconnect the power cable.

(5) Grounding Instructions Shall Include the Following

This product must be grounded. In the event of an electrical short circuit, grounding reduces the risk of electric shock. This product is equipped with a cord that has a grounding wire and an appropriate grounding plug. The plug must be plugged into an outlet that is properly installed and grounded in accordance with all local codes and ordinances.

If repair or replacement of the cord or plug is necessary, connect the ground wire to the ground terminal of the plug. The wire with green insulation (with or without yellow stripes) is the grounding wire.

Check with a qualified electrician or service person if the grounding instructions are not clear or if in doubt about the proper grounding of the machine. Do not modify the plug provided; if it will not fit the power outlet, have the proper outlet installed by a qualified electrician.

DANGER!

Improper installation of the grounding can result in electrocution

4. Machine Information

(1) Areas of Application and Machine Description

This plastic strapping machine can be used for all types of strapping applications with package sizes of 100 mm(width) × 20 mm(height) and up.

This machine is particularly suitable for heavy packaged goods as well as printed products, boxes, etc.

Machine Description

Automatic plastic strapping machine for use with polypropylene strapping

Extra tough construction

Simple, safe and user-friendly operation

Mobile, with large table area and high capacity strap reel

Table surface made of stainless steel

Mechanical outside tension control

Environment Information

The strapping machine shall be installed in the following conditions:

- Supply voltage: 0.9 - 1.1 nominal supply voltage
- Source frequency: 0.99 - 1.01 nominal frequency
- Ambient temperature: 5°C - 40°C (41°F-104°F).
- Relative humidity: not exceed 50% at 40°C.
- Please provide a suitable illumination around the machine for safety operation.

(2) Technical Data

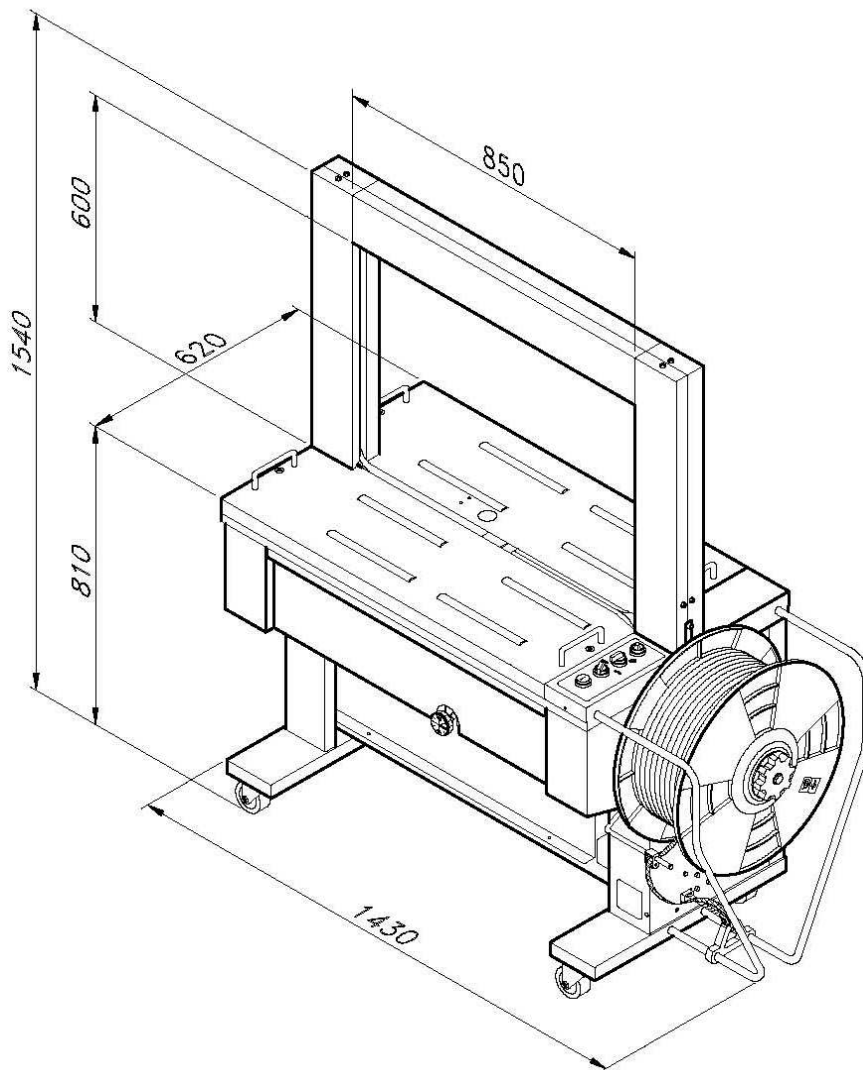

Sealing method :	Heat
Strap width :	8 mm to 15.5 mm (3/8" - 5/8")
Strap thickness :	0.55 mm up to 0.75 mm (0.022" - 0.03")
Strap reel diameter :	200 mm (8" nominal)
Width :	1430 mm (56.3")
Depth :	620 mm (24.4")
Table height :	810 mm (31.9")
Electrical connection :	AC 110V/220V/230V/240V (50/60Hz), 1PH AC 220V/380V/400V (50/60Hz), 3PH
Weight :	220 kg (341.7 lbs.)
Noise emission :	83 dB (A)
Ambient temp :	5°C ~ 40°C (41°F ~104°F)

(3) Control Panel

a. (For Standard Version)

① Start Switch

This is the switch to start a strapping operation. A strapping cycle is completed only after actuation of this switch.

② Stop switch

Push the stop switch in case of emergency. Simply push this stop switch to completely stop the strapping operation.

* Lock stop switch if strapping has to be interrupted for a short period of time. The machine will stop but the heater element will maintain its temperature. The machine will then be immediately ready for operation without need for warming-up of the heater element.

③ F/R switch

(Feed and Reverse)

After P.P. strap is fed and the power supply switch is on, turn this switch counterclockwise to feed P.P. strap around arch. When the switch is turned clockwise, P.P. strap reverses and returns strap from the arch track to the accumulator box.

④ Power supply switch and pilot lamp

When the power supply switch is turned on, the pilot lamp lights up, showing that electric power is being supplied.

⑤ Auto/Hand selector switch

While selector switch is placed to the position "AUTO", the machine will automatically strap the package when it is placed on the table and passes the arch, (the strapping cycle will continue, if the package remains under the arch.) While the selector switch is placed to the position "HAND", after positioning the package under the arch, push the "START" switch, then one strap will be applied.

⑥ Reset switch (Option)

If the machine is with short feed sensor (Page 6 of part II), When strap no at home position sealing This switch has reset function.

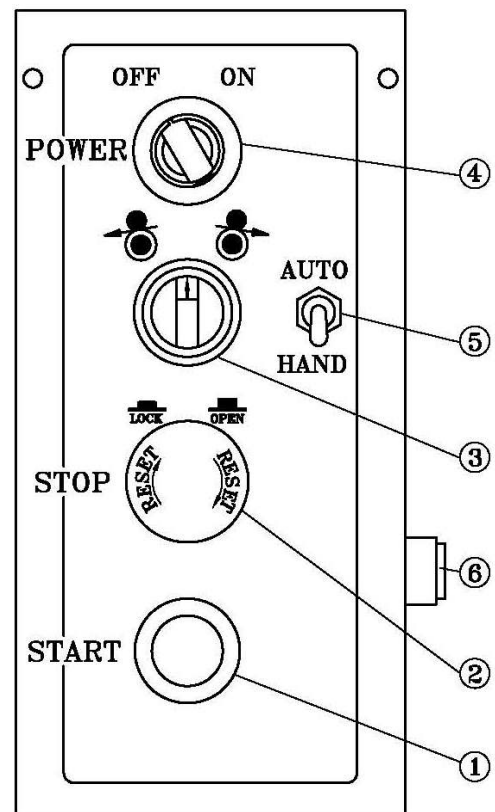

b. (For CE Version)

① Start switch

This is the switch to start a strapping operation. A strapping cycle is completed only after actuation of this switch.

③ F/R switch

(Feed and Reverse)

After P.P. strap is fed and the main power switch is on, turn this switch counterclockwise to feed P.P. strap around arch. When the switch is turned clockwise, P.P. strap reverses and returns strap from the arch track to the accumulator box.

④ Power pilot lamp

When the main power switch is turned on, the pilot lamp lights up, showing that electric power is being supplied. If the machine has the short feed sensor, when strap no at home position sealing this switch has reset function and lights up if under power.

⑤ Auto/Hand selector switch

While selector switch is placed to the position , the machine will automatically strap the package

(The strapping cycle will continue, if the package remains under the arch.) While the selector switch is placed to the position , after positioning the package under the arch, push the "START" switch, then one strap will be applied.

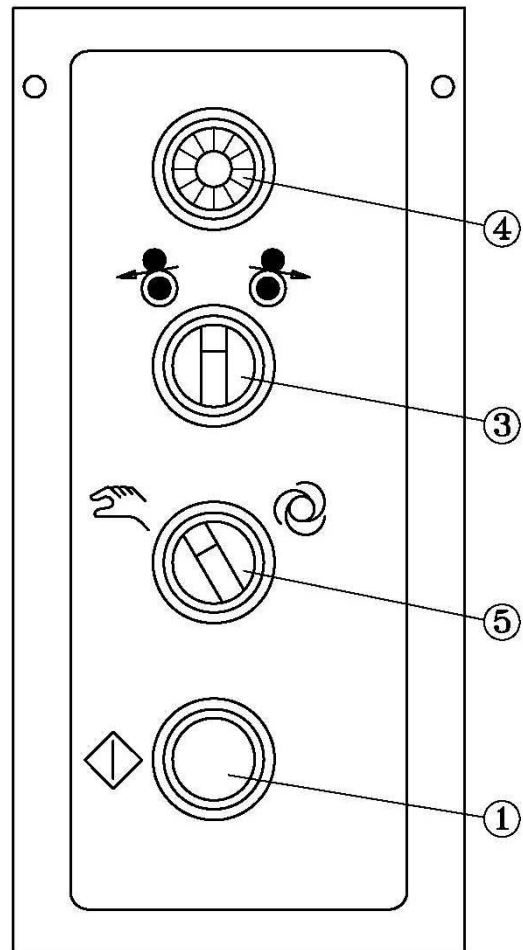

(4) Electric Control Unit

a. (For Three Phase)

Magnetic switch ⑥

This is a current protection device. In case of overload, the over load relay will cut off power automatically. For normal operation, please actuate this switch.

Timers ⑦ & ⑧

Timer , T1 ⑦ :

This Timer, T1, determines the time necessary for strap take-up.

While setting, please test with the minimum sized package. Normally, Timer T1 is set at about 0.4 second, but may have to be adjusted depending on arch size & actual package size.

Timer , T2 ⑧ :

This Timer, T2, determines the time necessary for strap feed.

If the time selected for Timer T2 is too short, strap may not reach the sealing position. Normally, Timer T2 is set to about 0.8 second for standard arch (850x600), but may have to be adjusted depending on arch size.

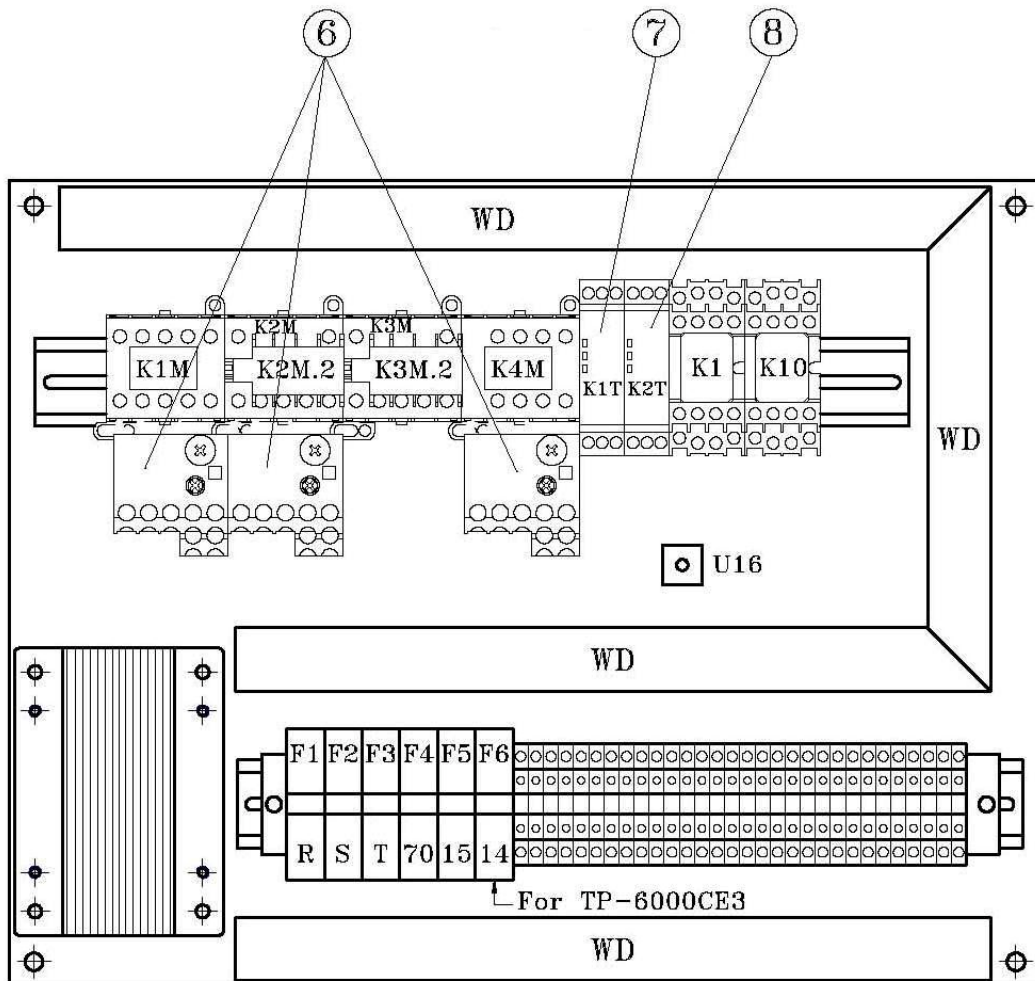

TP-6000-3
TP-6000CE3

b. (For Single Phase)

Timers ③⑩ & ②⑨

Timer, T1 ③⑩ :

This Timer, T1, determines the time necessary for strap take-up. While setting, please test with the minimum sized package. Normally, Timer T1 is set at about 0.3 second, but may have to be adjusted depending on arch size & actual package size.

Timer, T2 ②⑨ :

This Timer, T2 determines the Time necessary for strap feed. If the time selected for Timer T2 is too short, strap may not reach the sealing position. Normally, Timer T2 is set to about 0.7 second for standard arch (850x600), but may have to be adjusted depending on arch size.

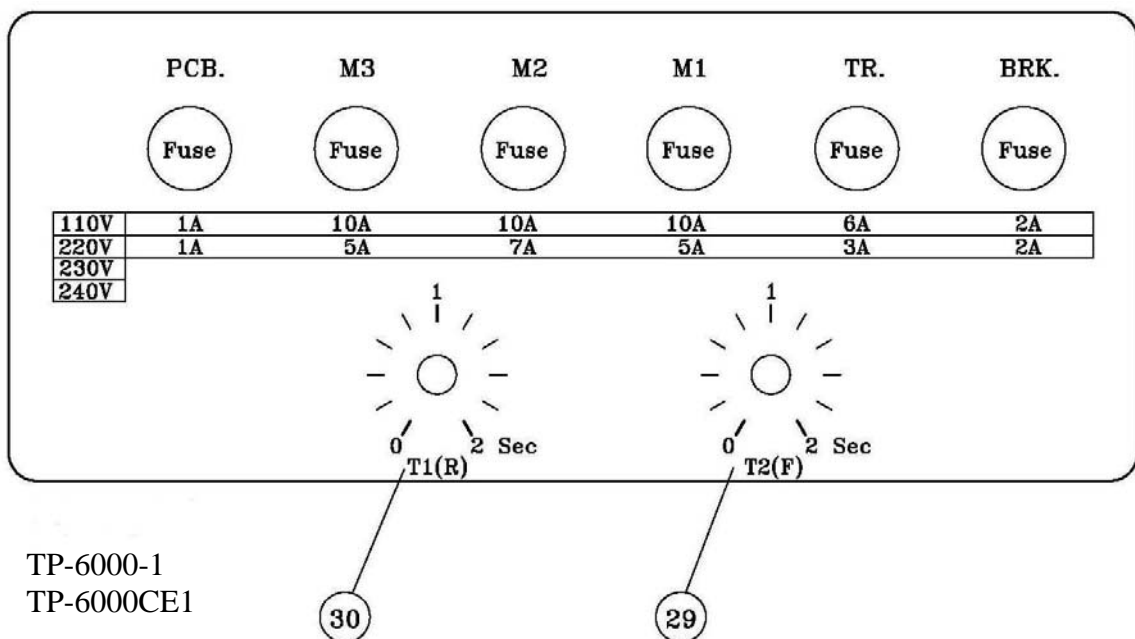

5. Operating the Machine

(1) Operation Space

Keep the area (A) and (B) free for the operator.

The area (A) is necessary for operation strapping machine and the area (B) is necessary for changing the strap or adjusting strap amount in the accumulator.

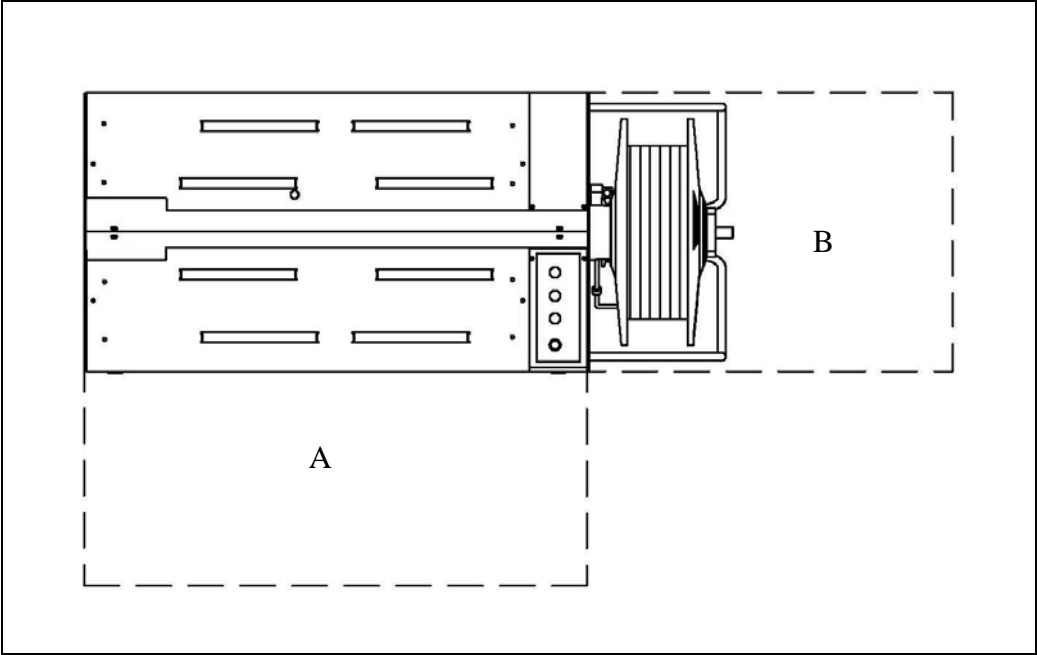

(2) Installation of Arch Unit

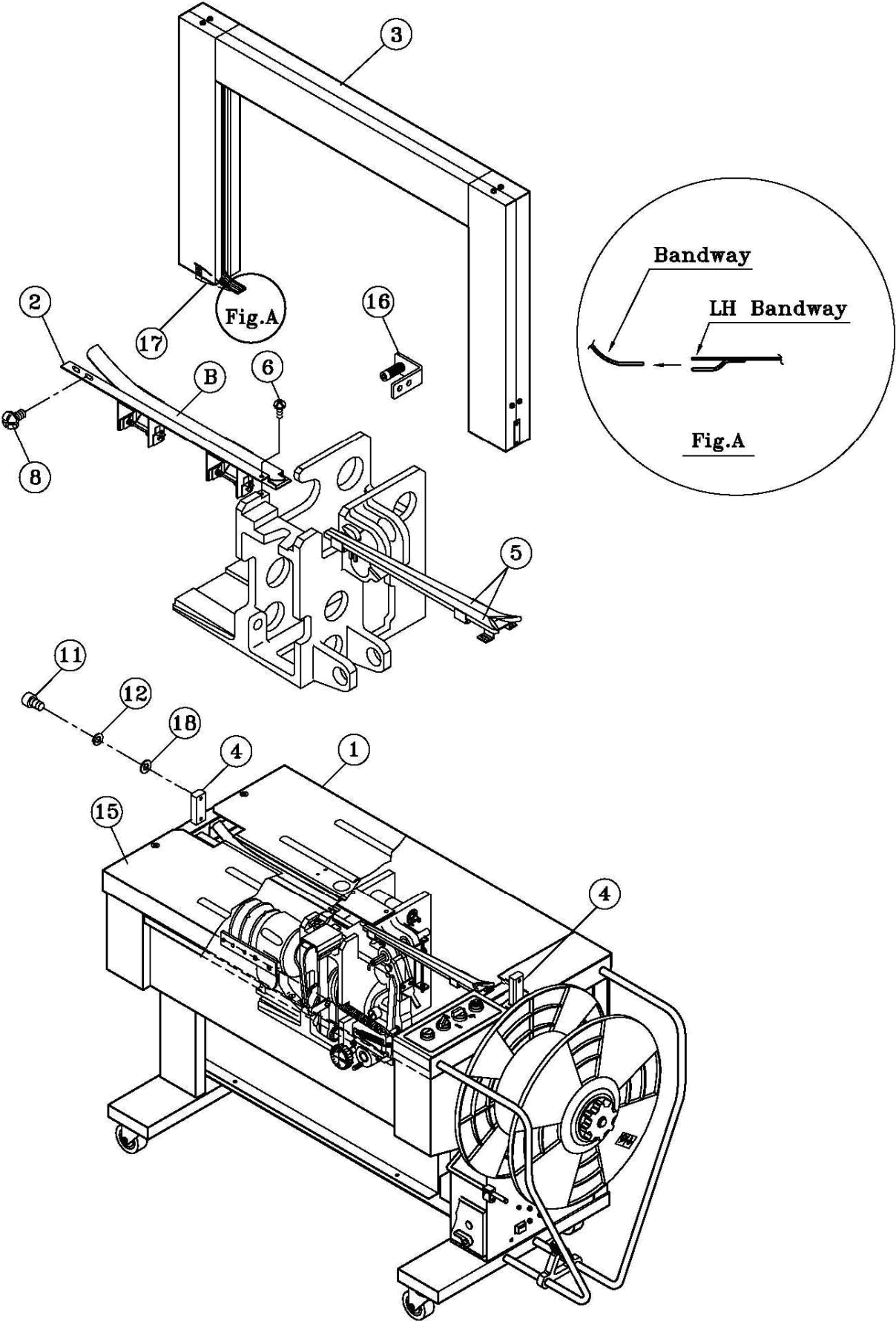

a. Take the upper table ①, ⑮ off.

b. Take the LH bandway ② off.

⑥ TMS, M5×8 1PC

⑧ TMS, M6×8 2PC

⑪ HBS, M8×15 4PC

⑫ SW, M8 4PC

⑱ PW, M8 (A) 4PC

c. Slide the arch unit ③ into the fixing brackets ④ and fix both sides of the arch frame with ⑪ ⑫ ⑱.

* Please note that it is imperative to open the flaps of RH bandway ⑤ to protect them when installing the arch unit in. (open the flaps, before inserting the arch unit in).

d. Set the LH bandway ②, with ⑥ and ⑧.

d-1. Please note that the arch bandway (refer Fig. A) should be positioned between LH bandway and its fixing bracket.

d-2. Please set the LH bandway ② closely to ⑰ guiding angle (PART NO. T6-2-21260).

d-3. Push the ⑯ Band guide Spring Bracket backward to check if B will be automatically turned open. If so, the installation is OK.

e. Position the upper table ① ⑮ onto the machine body.

(3) How to Load P.P. Strap

- Ensure that the power supply switch is turned off before loading P.P. strap.

Step 1

Place a strap coil on the reel drum according to the arrow direction as indicated on the Outer Flange (9). After sliding on the coil, put the Outer Flange on the strap coil and tighten it using the Reel Nut Handle (10).

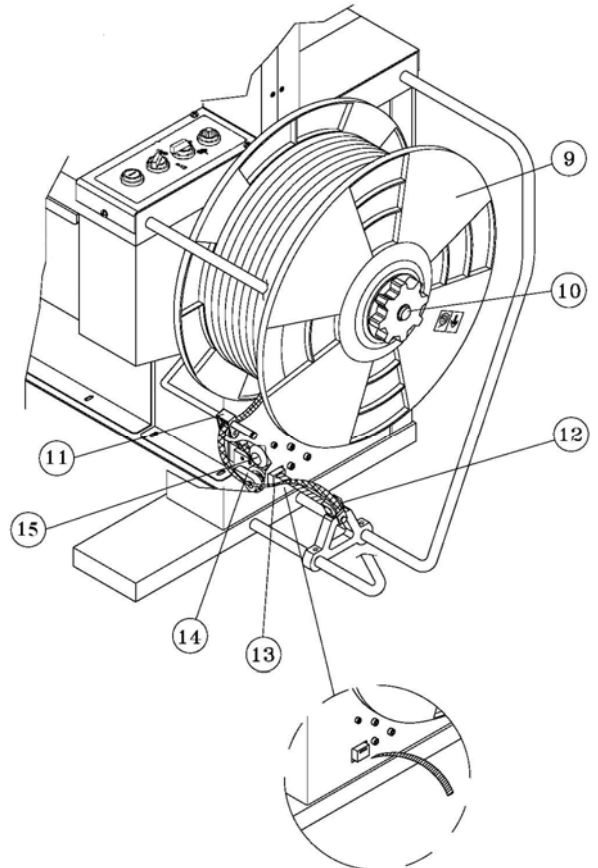

Step 2

Thread the tip of the P.P. strap into the Strap Guide Roller (11). After that, push it through the Guiding Angle (12). At this moment, twist the strap so that the inside part of the P.P. strap turns out downward and the outside touches the roller. See drawing.

Step 3

Open the door of Accumulator Box (16). Insert P.P. strap into the Accumulator Feed Shooter (13), pushing the lever (14) downward. Pull out about 1m of strap through the Accumulator Feed Shooter (13) and insert it into the narrow passage of the Accumulator Box.

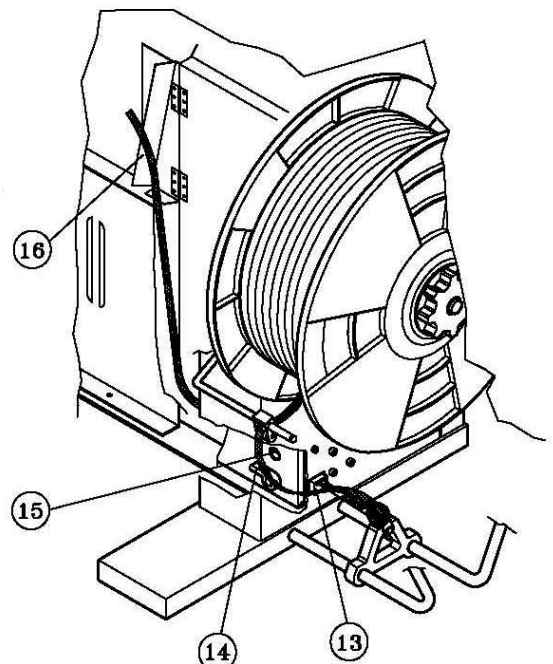

Step 4

Turn the Upper Roller Grip (18) to the left hand side, while pushing the strap tip of strap under the Strap Cover (17). By turning the upper roller grip, the strap will pass between the Upper Feed Roller (19) and the Feed Roller (20).

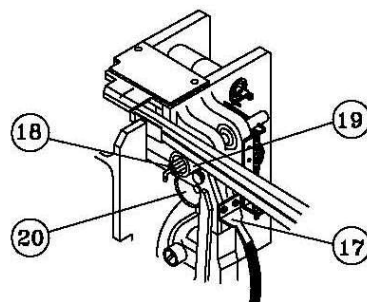

(4) How to Operate

- a. For standard version :

Turn the power supply switch on. The pilot lamp lights up and the strap is automatically fed into the Accumulator Box. (See part I page 9 ④)

For CE version :

Turn on the Main power switch (make a 90-degree clockwise turn). The front door will be locked at the same time. [If you want to open the front door, turn off the main power switch first (make a 90-degree counterclockwise turn). In this way, the operator can open the front door without risk.] (See drawing below)

- b. Turn F/R switch counterclockwise. P.P. strap is fed into the arch track. Keep turning the F/R switch until the strap reaches the sealing position. It is now ready for strapping.
- c. Wait for about 3 minutes until the heater element reaches its required operating temperature.
- d. Place a package on the center of the strapping head.
- e. Push start switch (see part I page 9 ① or page 10 ①) or actuate foot pedal switch to start strapping. The strapping operation is repeated if the start switch is pushed again.
- f. After operation, turn off the power supply switch.

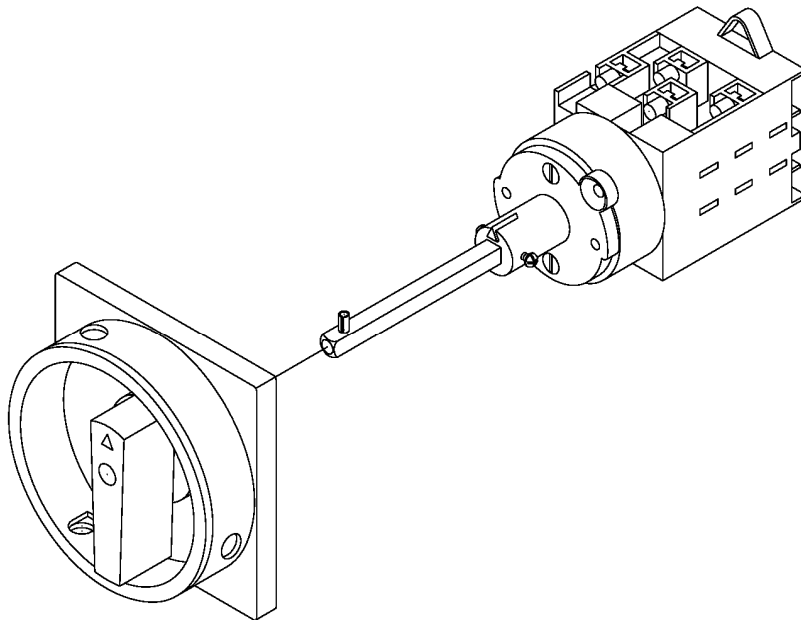

6. Adjustments

(1) Tension strength

The tension knob is used to adjust the tension strength for strapping. The range of strapping tension is 0-10, so that an operator can choose the adequate strapping tension for a package. Normally, the knob position 4 or 5 is suitable for a carton box.

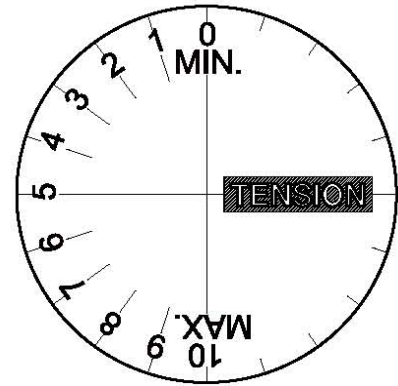

(2) Heater temperature

Set the knob to position 3 or 4. Adjust the heater temperature by selecting a position between 1 and 6. Choose the suitable temperature, bearing in mind the environmental conditions of the machine. If the heater temperature is too high or too low, a proper seal will not be obtained. Gradually increase or reduce the position until obtaining an optimum seal.

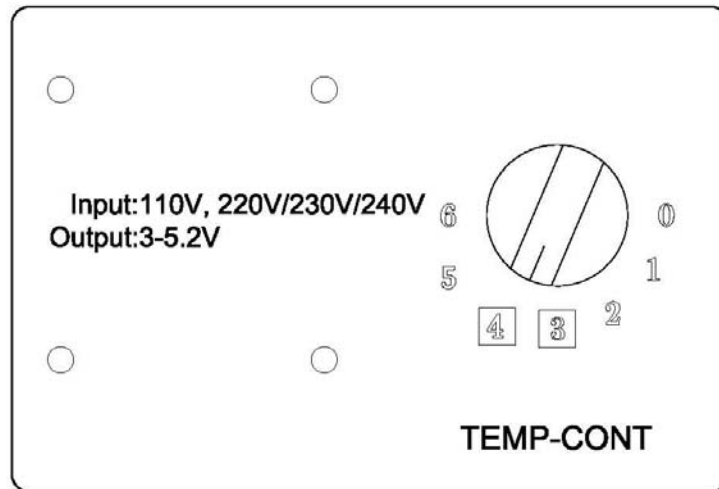

(3) Feed and take-up mechanism

If this unit is not correctly adjusted, strap feed and take-up will become irregular.

Normally, this unit is set to accept P.P. strap with the thicknesses of 0.55mm-0.6mm. If a different strap thickness is used, adjust the section marked by a circle in the drawing so that the clearance between the Upper Roller Spring (23) and the Upper Shaft Spring Hook (24) should be the thickness of the strap you are using. Strap can only be taken up properly if this unit is precisely adjusted. (If not, strap will be sealed before being tightened around the package) Moreover, strap will leave the chute arch track when feeding into it if there is no clearance.

- a. Check if the control unit returns to its home position. Insert the strap between Feed Roller (22) and Upper Feed Roller (21).
- b. Loosen 2 Bolts (27) holding the right-hand Block Arm (25) with the Press Arm Shaft (26). Press Arm Shaft can then easily be moved by hand.
- c. Adjust so that there is a clearance between the Upper Roller Spring (23) and the Upper Shaft Spring Hook (24) the same as the thickness of the strap you are using.
- d. Tighten 2 Bolts (27) .

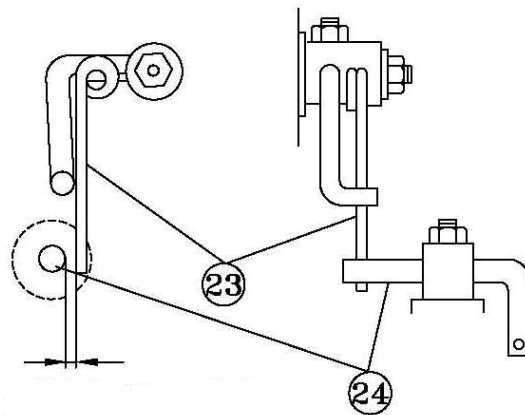
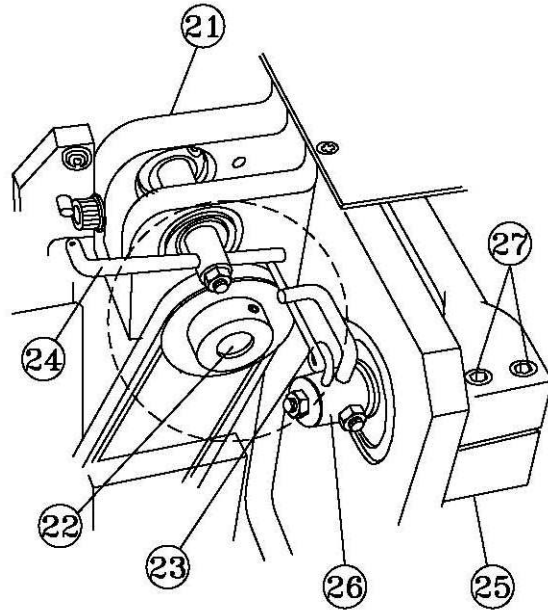

The thickness of the strap you are using

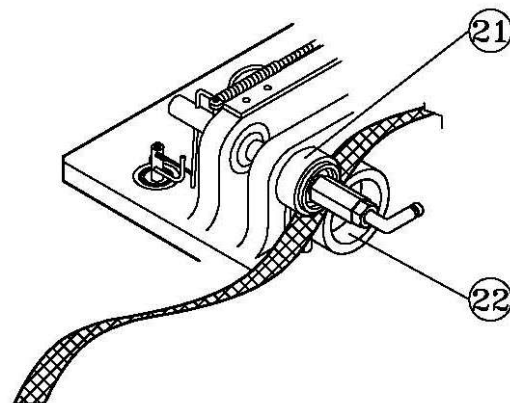

(4) How to adjust LS3, LS2, LS1 (Movements of control unit)

LS3, (31) controls the machine to stop at home position and is adjusted by Limit Switch Contactor, (32).

When LS1 is activated, the control unit stops and the strap starts reversing. In the control unit, the right Press Unit (37) rises up to the top and grips the strap under Slide Table, (38). Strap Guide, (39) moves backward and LH Strap Guide Flap, (40), opens completely. At this moment, cam follower, (41) stays at its position before it starts rising on the Tension Cam, (42). The illustration shows the correct position of control unit with correct adjustment of LS1, (33). LS1 is adjusted by Limit Switch Contactor, (34).

The strap feed cycle is triggered by LS2, (35). To activate LS2, (35), correctly, adjust limit switch contactor, (36), so that the cam follower, (41), starts descending along the tension cam, (42).

LS-3

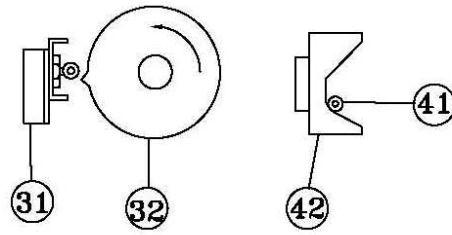

LS-1

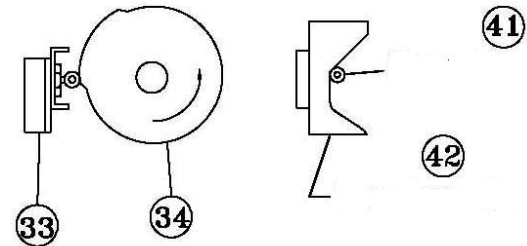

LS-2

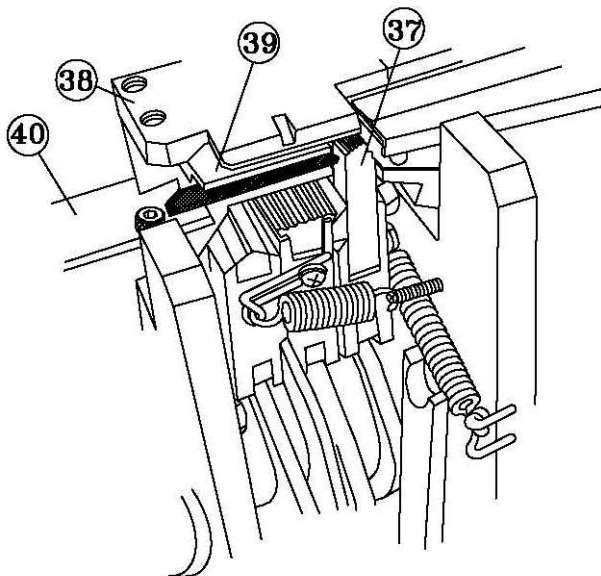
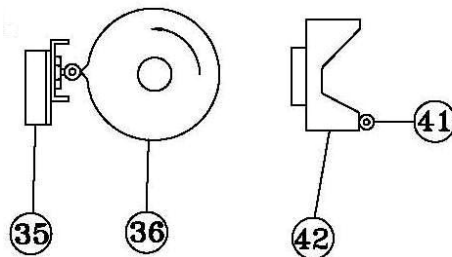

(5) Amount of strap in Accumulator Box

The machine has already been set in its Accumulator Box.

However, some adjustment may be required, depending on the actual quality or thickness of the strap used. If adjustment is necessary, proceed as shown in the following drawing.

- a. In case that there is an insufficient amount of strap in the Accumulator Box, loosen the Nut (27) and turn the Screw Bolt (28) counterclockwise.
- b. In case that there is an excessive amount of strap in the Accumulator Box, loosen the Nut (27) and turn the Screw Bolt (28) clockwise.

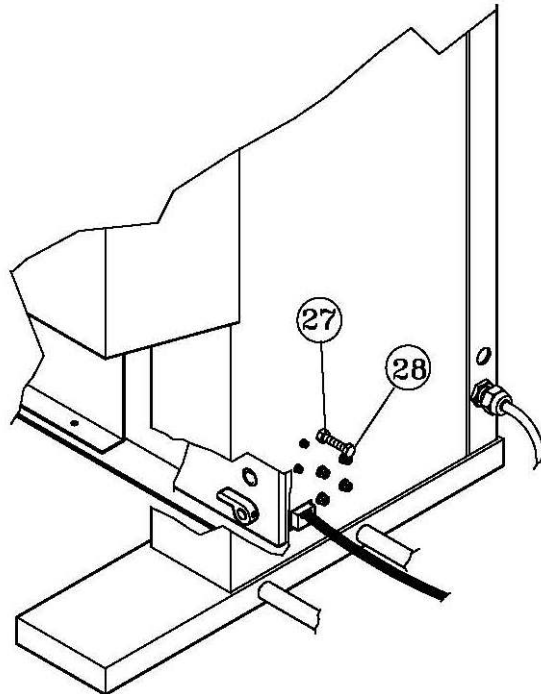

7. Maintenance

Warning:

Before any maintenance or repairs on the machine, set the Main Power Switch to "O" (OFF). Wait about 3 minutes for cooling down the heater to avoid burns with this area.

(1) Cleaning and Lubrication

The high reliability and long service life of the strapping machine will depend on regular cleaning and maintenance.

ATTENTION!

All the important strap transport components, such as the feeding rollers and the strap guides, must be kept free from oil and grease. (lubricant)

The lubricant has to be non-resinous.

The lubricant is SAE 30

(2) Maintenance

Only use original spare parts supplied by manufacturer.



Daily:

Use air gun to clean the circled positions (nearby the cutters, strap guide and accumulating feeding rollers) daily

Remove plastic residue in the machine.

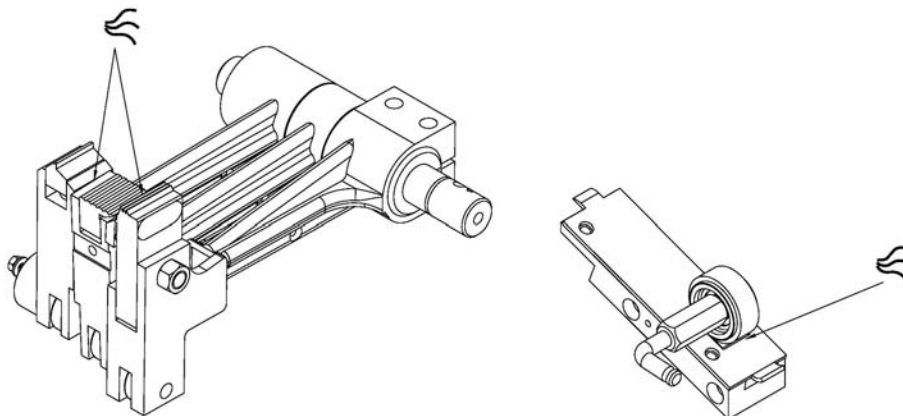

Monthly :(or 50,000 strapping cycles)

Clean both sides of heater plate and polish with fine sandpaper if necessary

ATTENTION: Make sure the welding plate is cool first!!

Check supporting and cam rollers of strapping head for easy movement. The slide table must be moved back to home position automatically by the spring tension.

Be sure to clean any debris in the tension jaw.

6 Months: (or 300,000 strapping cycles)

Check heater plate, replace and readjust it if necessary.

Check strap cutter in strapping head, replace it if necessary.

Check that connector at wiring loom to printed circuit board is firmly fixed.

Make machine ready for operation. Strap one bundle manually several times, paying attention to mal-functions, repeat procedure.

Check strap accumulating function. Do proper adjustments to accumulating feeding pressure or the reel brake belt

1 year :(or 600,000 strapping)

Replace deflection roller if it shows visible changes.

In case of loud noise at bearings: locate them, replace the bearings.

Get machine ready for operation again, strap one bundle manually several times, paying attention to malfunctions.

NOTE: Any other service must be performed by an authorized service representative.

8. How to Safely move the Machine

- a. Before moving the machine, be sure to unplug the power cord and put it in safe place to avoid any damage.
- b. Moving the machine by holding the Reel Guard to pull or push the machine.

Note: Don't move the machine by pulling or pushing the arch unit.

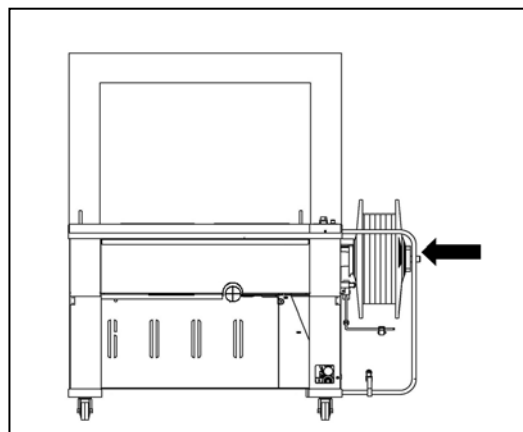

9. Troubleshooting

(1) Machine does not work

a. Pilot Lamp does "NOT LIGHT UP"

Probable Causes	Remedy
a1. No electrical supply a2. Fuse is blown or dislodged a3. Wire broken or disconnected	a1. Check electrical power source a2. Check electrical unit a3. Check wire

b. Pilot Lamp is "ON"

Probable Causes	Remedy
b1. Stop switch remains locked b2. Poor contact or break down of Start Switch or Stop Switch b3. One of 3 wires broken or disconnected b4. Belt of Motors is loose or is broke	b1. Turn the switch clockwise. b2. Change switch b3. Check wire or connector b4. Check and adjust or change belt

(2) Machine works

a. Improper strap tensioning

Probable Causes	Remedy
a1. Tension Adjusting Arm Spring broken or worn a2. Tension Jaw Spring is worn-out or dislodged a3. Value set for Timer T1 is too short	a1. Change Tension Adjusting Arm Spring a2. Change or reset Tension Jaw Spring a3. Adjust Timer T1 (see P11 or P12)

b. Incorrect strap feed and take-up

Probable Causes	Remedy
b1. Incorrect strap threading direction on reel holder	b1. Reload strap correctly (see P16)
b2. Incorrect loading of strap	b2. Check if strap is twisted in loading section (see P16)
b3. Strap gets in between strap coil and Reel Flange	b3. Reload strap
b4. Insufficient or excessive strap	b4. Adjust amount of strap accumulated (see P21)
b5. Dust and strap residues in Feed Unit	b5. Check and clean unit
b6. Strap end is split	b6. Adjust Cutter Tension Spring or change cutter
b7. Loose strap at Reel Unit	b7. Adjust or change Brake Tension Arm Spring
b8. Strap jumps out of arch track	b8. Adjust F/R mechanism (see P19)
b9. Poor quality of strap	b9. Cut off the damaged part of strap or change the roll
b10. Improper positioning of package on Table Top	b10. Replace the package in the center of the Sealing Head
b11. Tension Jaw does not return to its original position	b11. Change or reset Tension Jaw Spring
b12. Value set for Timer T2 is too small	b12. Adjust Timer T2 (see P11 or P12)

c. Strap unsealed

Probable Causes	Remedy
c1. Wire inside or outside of Heater of Heater is broken, loose or out of connect	c1. Check wire or change Heater
c2. Improper setting of temperature	c2. Adjust Heater Temperature (see P18)
c3. Strap does not reach the sealing point completely	c3. Adjust Limit Switch LS-3 (see P20)
c4. Value set at Tension knob is too high	c4. Adjust Tension knob (see P18) or increase weld cooling time

10. Wiring Diagram

a. TP-6000-1/TP-6000-CE1

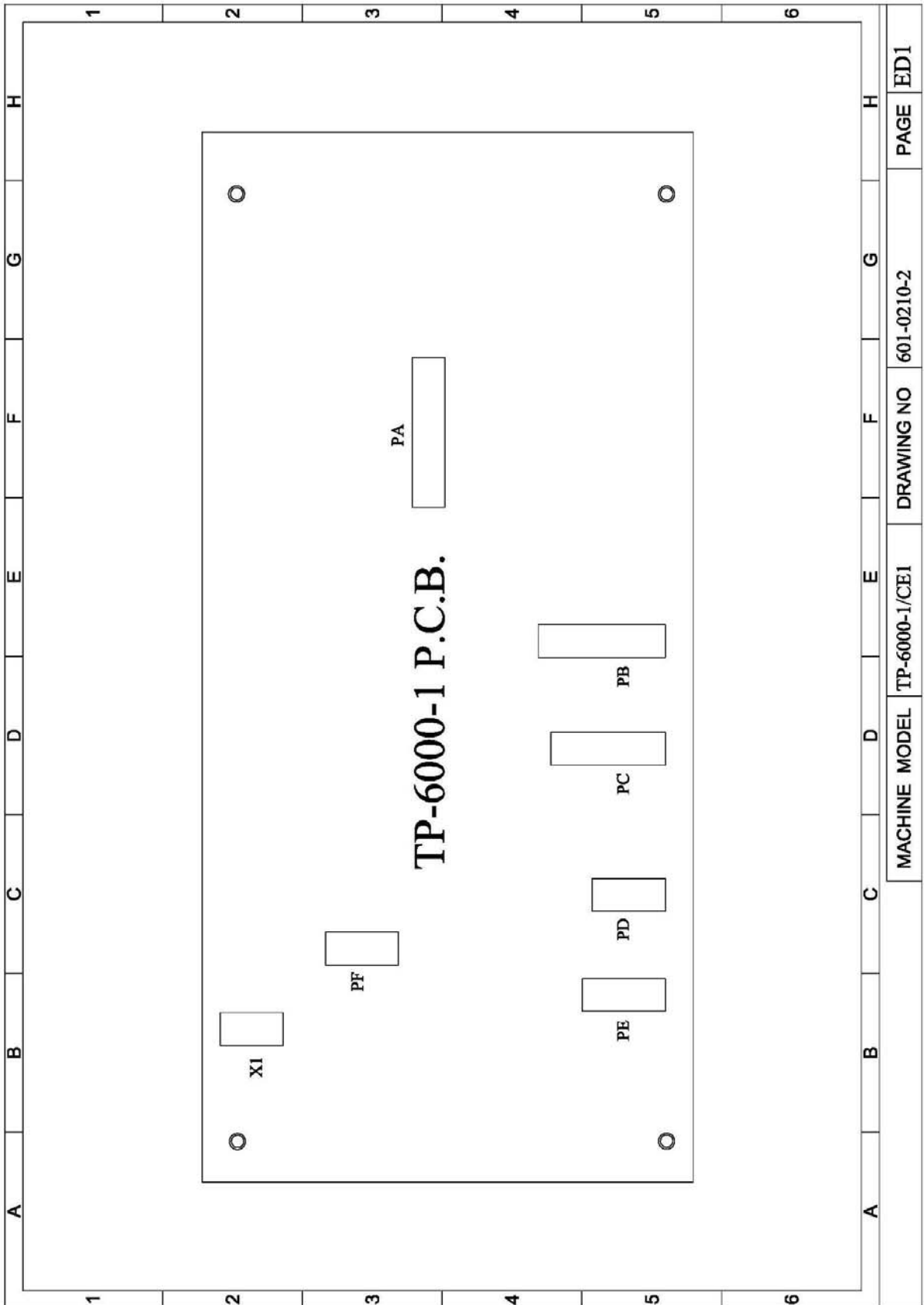

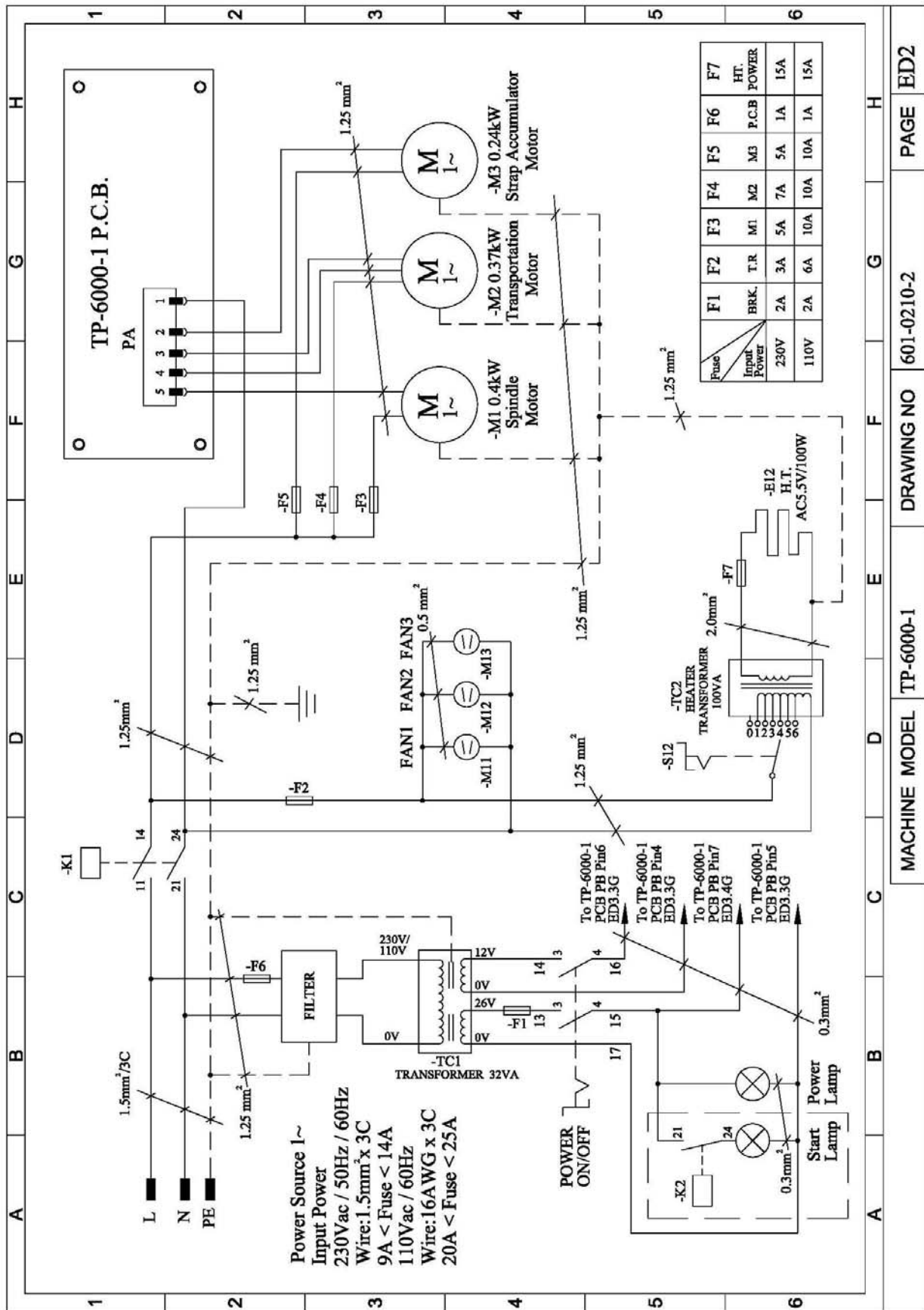

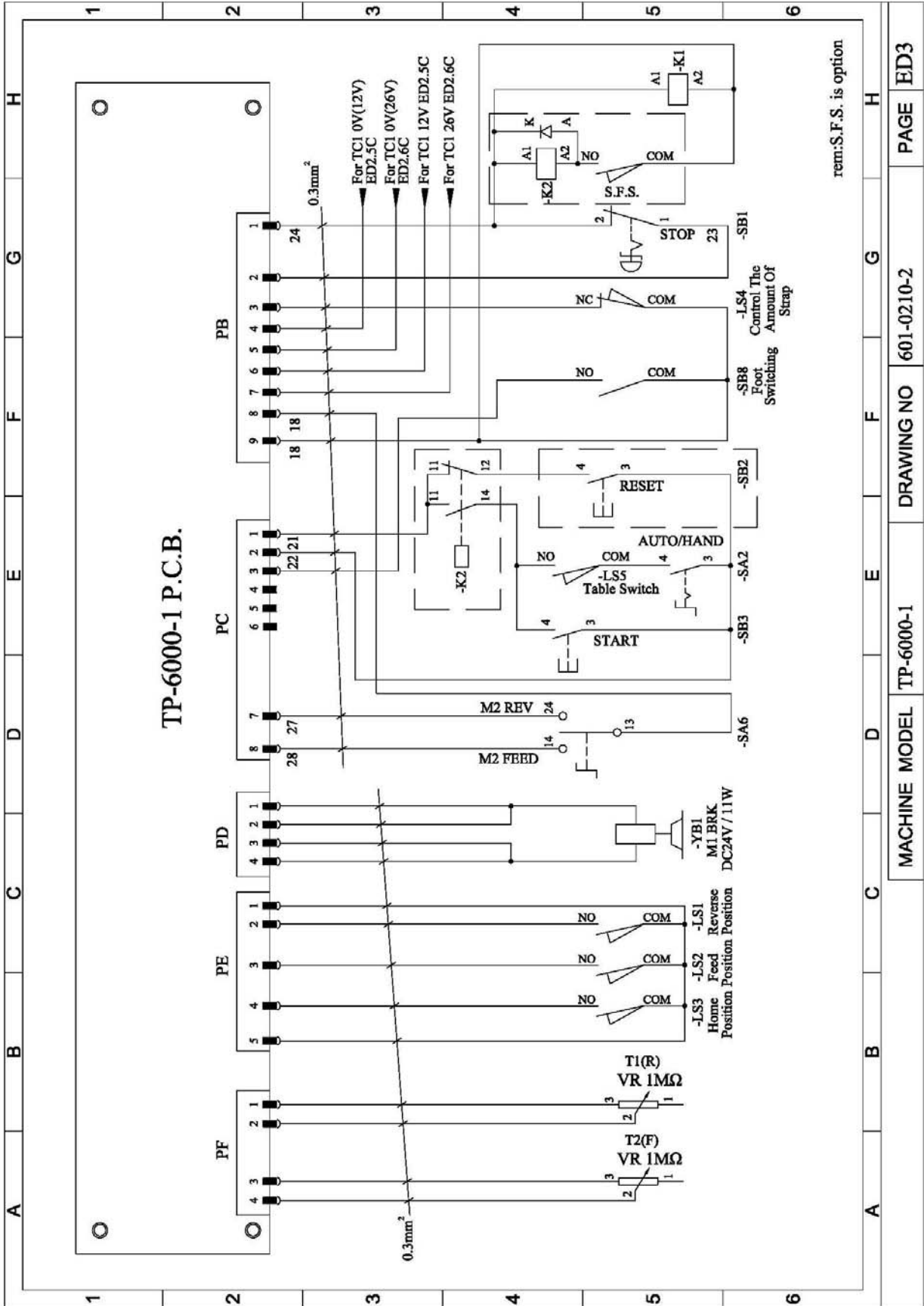

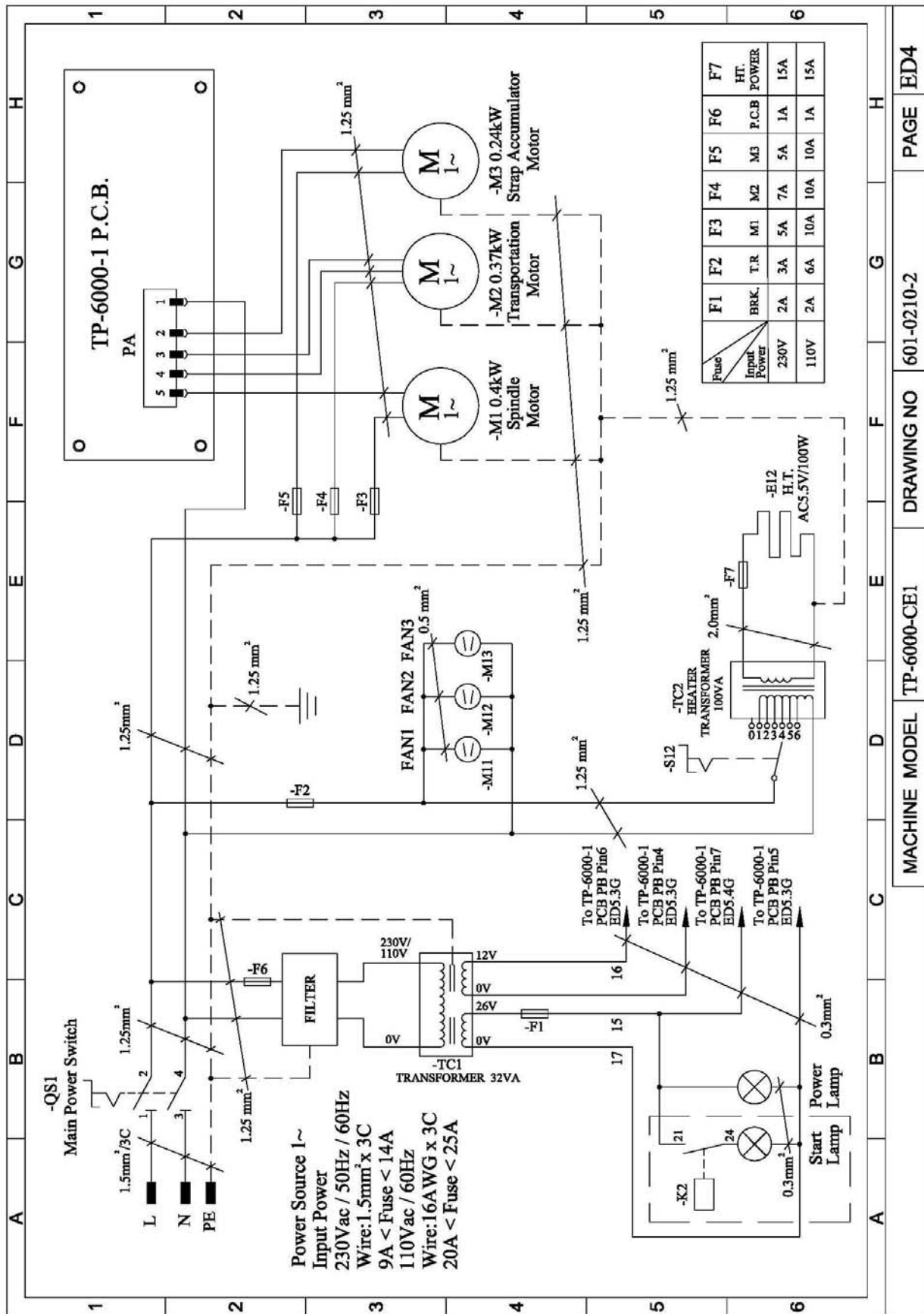

MACHINE MODEL TP-6000-CE1

DRAWING NO 601-0210-2

PAGE ED4

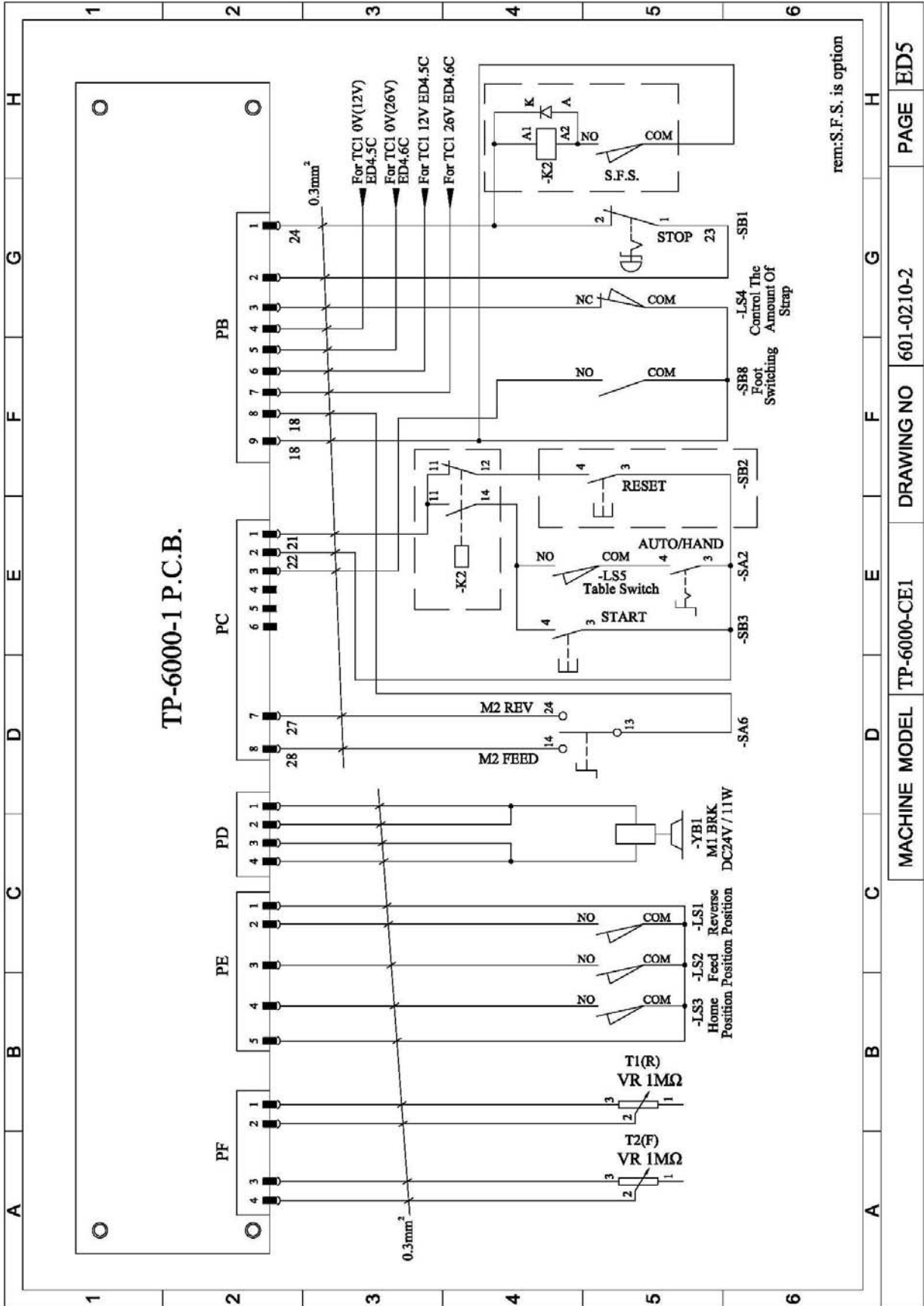

b. TP-6000-3/TP-6000-CE3

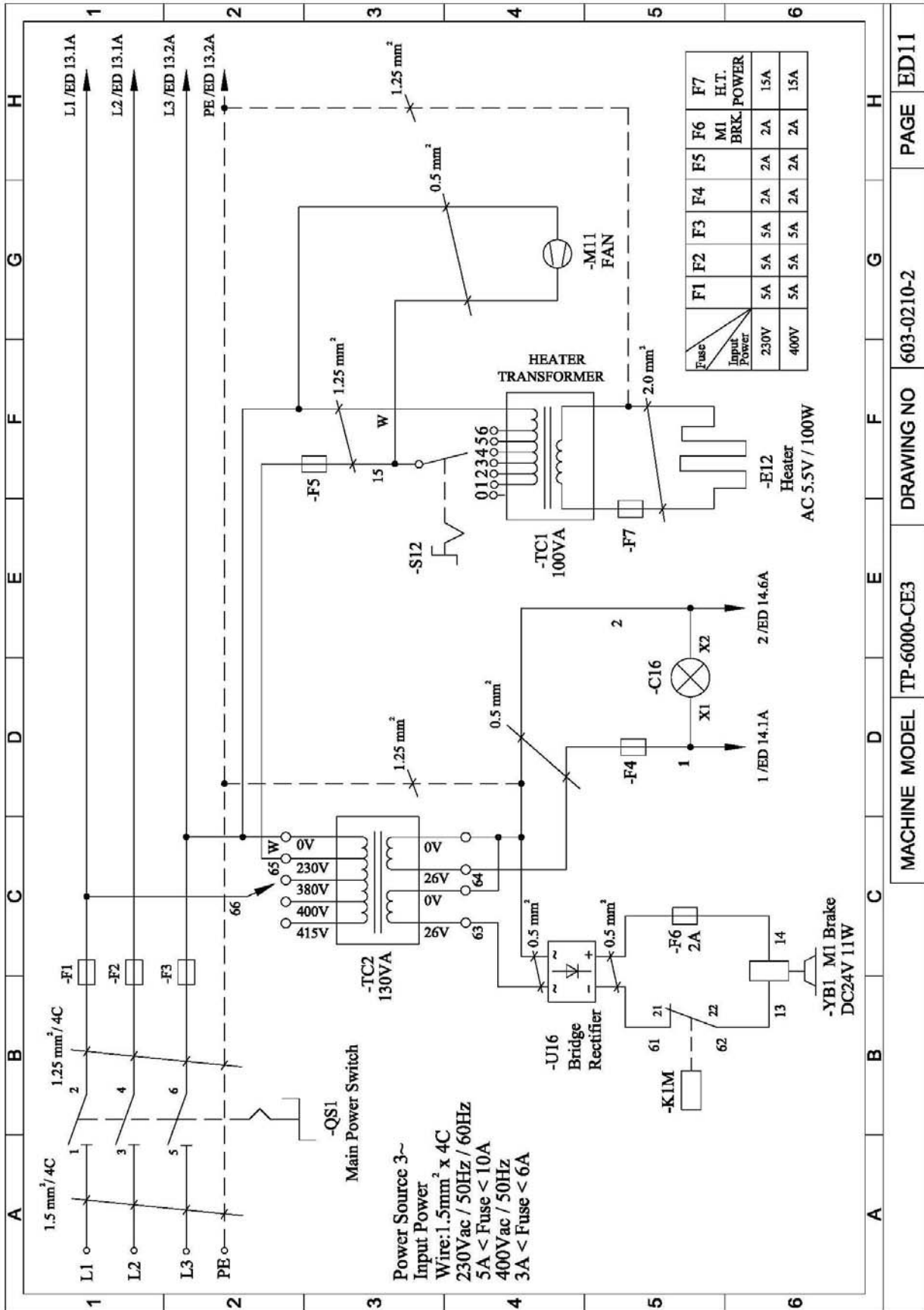

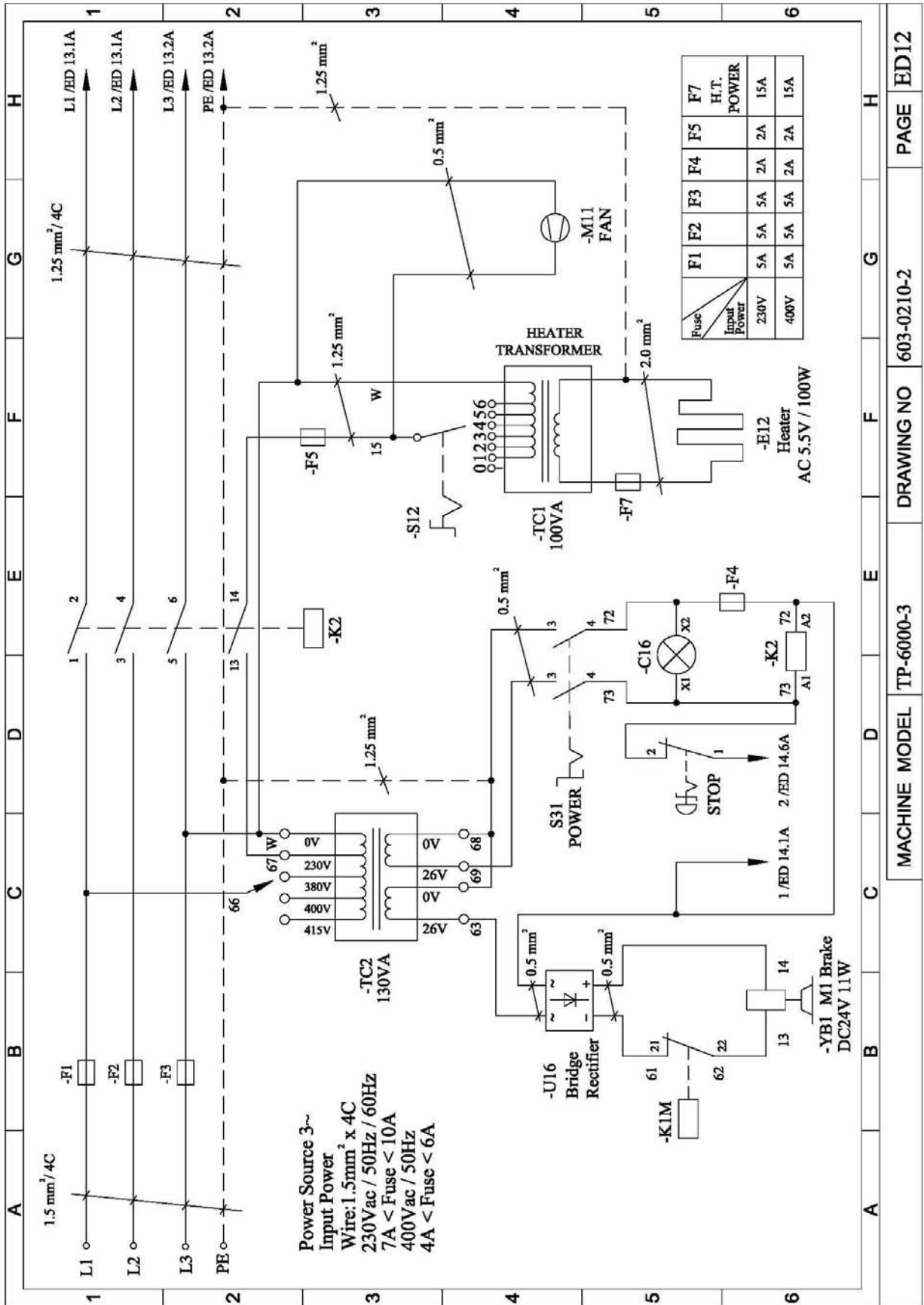

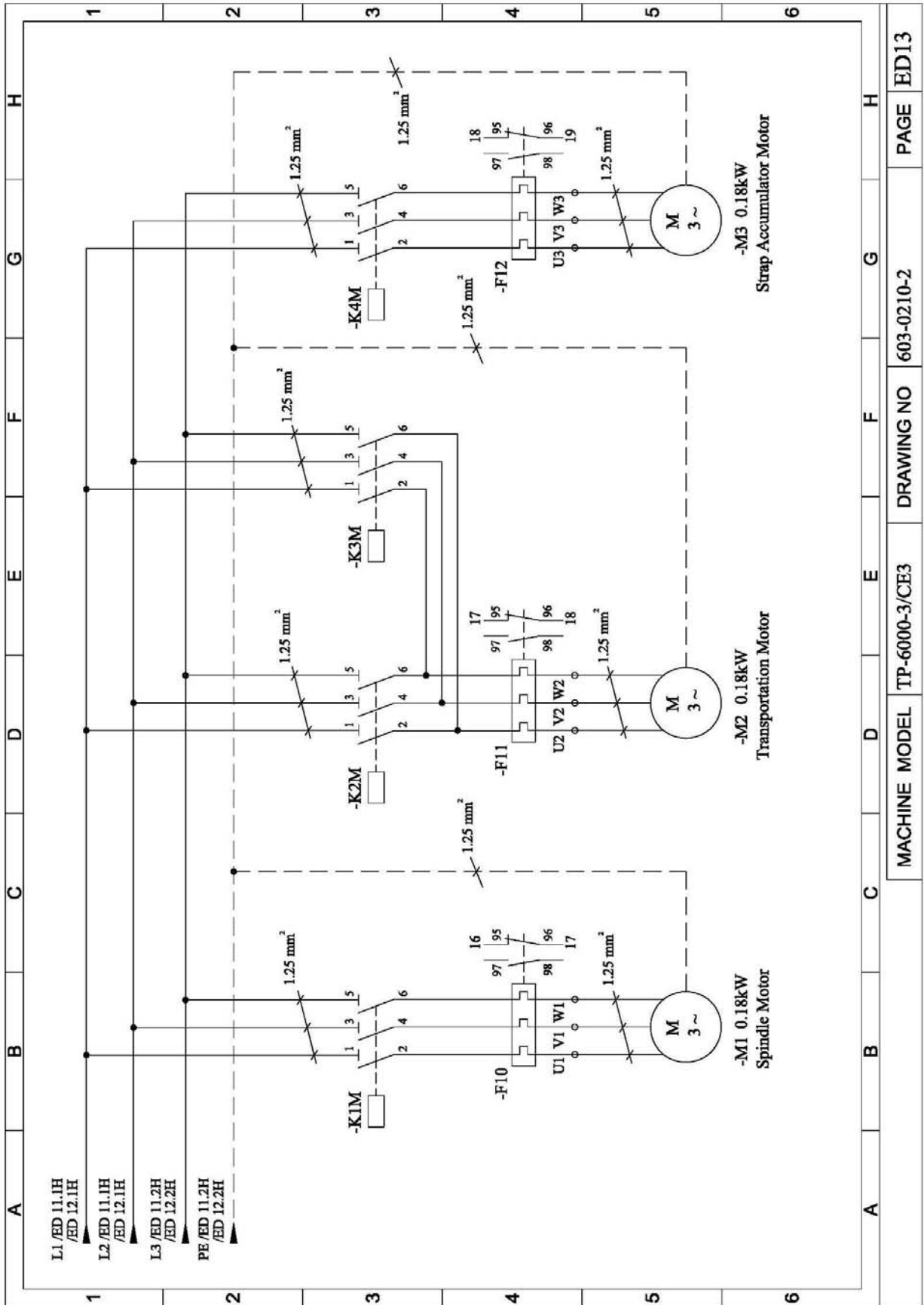

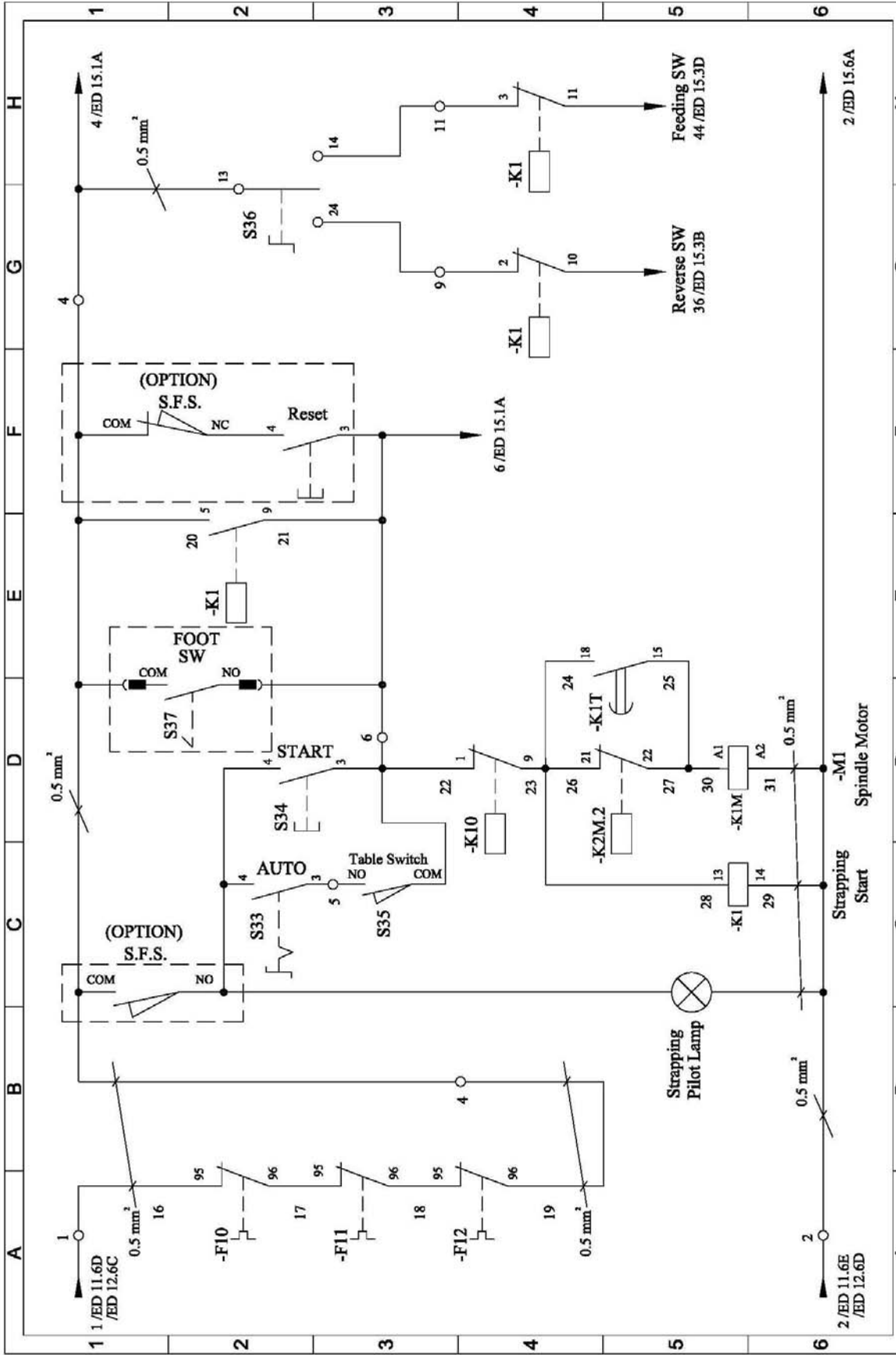



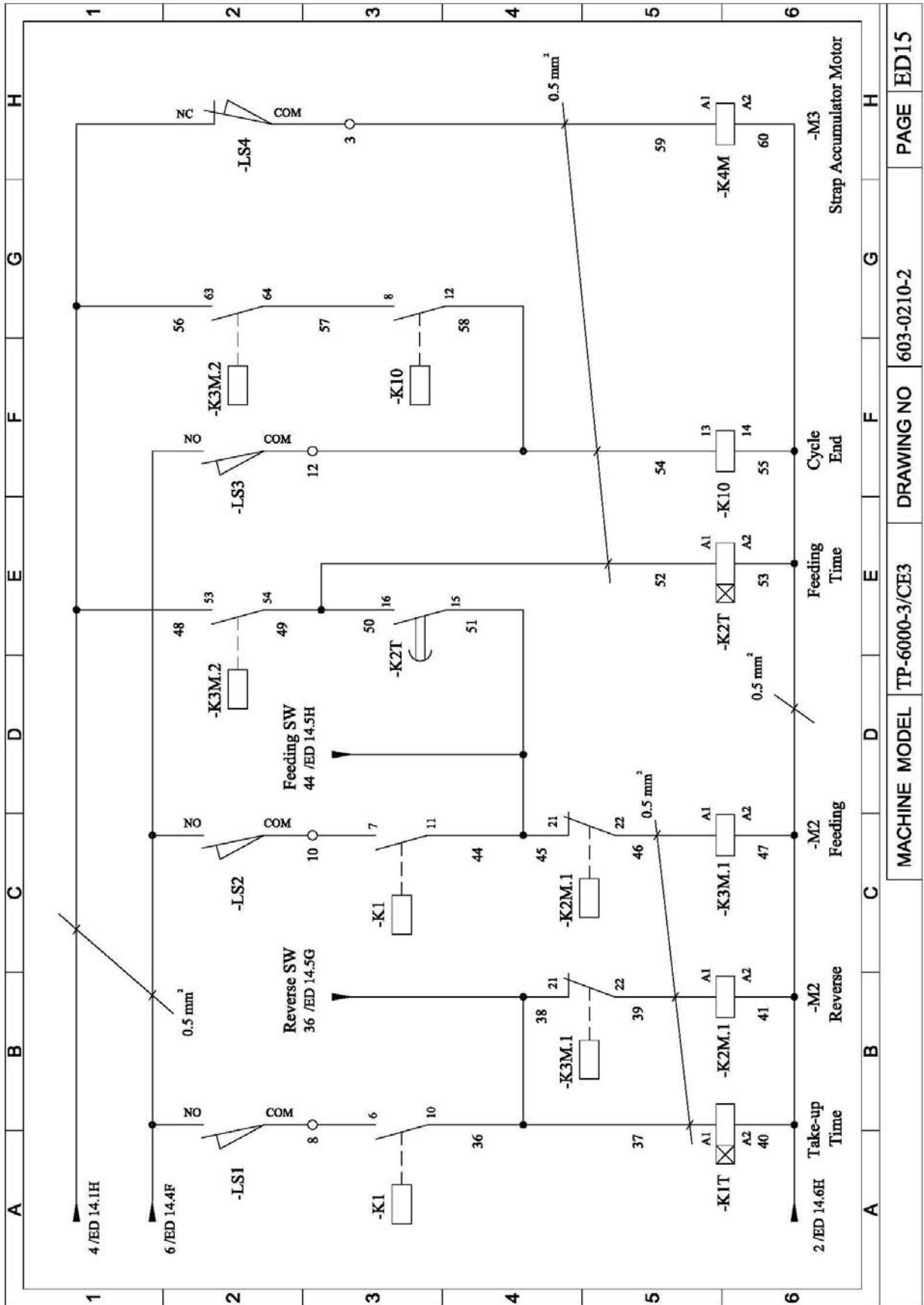































A	B	C	D	E	F	G	H
1	2	3	4	5	6		
MACHINE MODEL TP-6000-3/CE3				DRAWING NO 603-0210-2		PAGE ED14	



MACHINE MODEL	TP-6000-3/CE3	DRAWING NO	603-0210-2	PAGE	ED15
---------------	---------------	------------	------------	------	------

shape	classification	shape	classification
	HBS		ER
	TMS		RR
	PMS		SR
	FMS		SP
	HB		BR
	THS		MB
	HSS		KYA
	CAP		KYB
	HN		KYC
	WN		HBW
	FLG		PWA ϕ 8x ϕ 12~ ϕ 16x0.8~1.2t ϕ 6x ϕ 13~ ϕ 14x0.8~1.2t
	NTE		PWB ϕ 8x ϕ 14~ ϕ 16x1.2~1.5t ϕ 6x ϕ 15~ ϕ 16x1.2~1.5t
	PN		PWC ϕ 8x ϕ 20~ ϕ 23x2.0t ϕ 6x ϕ 16~ ϕ 19x2.0t
	PW		PWD
	SW		DS
	TW		TTP
	BWW		FTP

PART II

CONTENTS

1. Strapping Head Unit	1
2. Bandway Unit	34
3. Accumulator Unit	49
4. Reel Unit	59
5. Body Frame Group	67
6. Electric Control Unit.....	88

1

STRAPPING HEAD UNIT

T6-1-90000

T6-1-90012

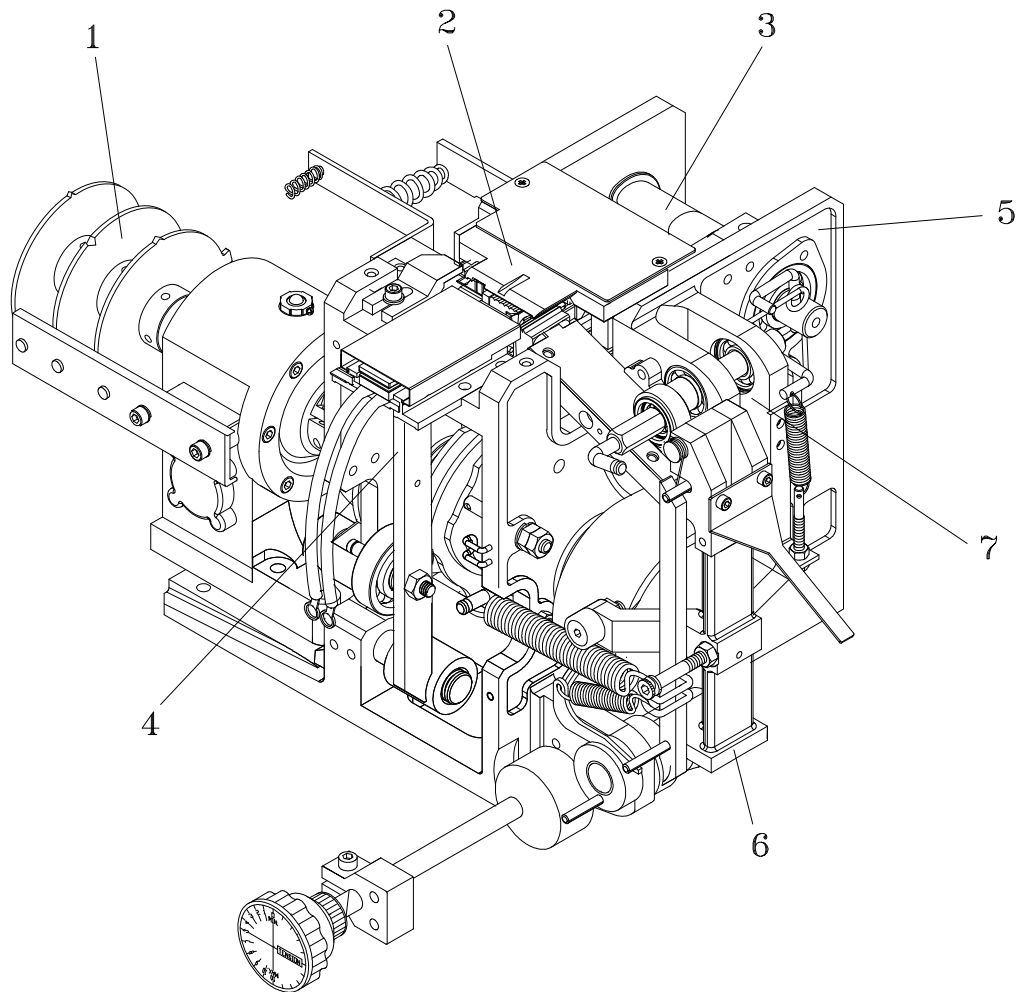

REF. NO.	PART NO.	DESCRIPTION	Q'TY	REMARKS
	T6-1-90000	Strapping Head Unit (For 12mm)	1	
	T6-1-90000S	Strapping Head Unit (For 12mm) (Stainless Steel Model)	1	
	T6-1-90012	Strapping Head Unit (For 9mm)	1	
	T6-1-90012S	Strapping Head Unit (For 9mm) (Stainless Steel Model)	1	
	T6-1-90013	Strapping Head Unit (For 15.5mm)	1	
	T6-1-90013S	Strapping Head Unit (For 15.5mm) (Stainless Steel Model)	1	
1	T6-1-10006	Cam Group (For 1PH)	1	SEE PAGE 3
	T6-1-10007	Cam Group (For 3PH)	1	SEE PAGE 3

REF. NO.	PART NO.	DESCRIPTION	Q'TY	REMARKS	
2	T6-1-20005	Slide Table Group (For 12mm)	1	SEE PAGE 6	
	T6-1-20005S	Slide Table Group (For 12mm) (Stainless Steel Model)	1	SEE PAGE 6	
	T6-1-20006	Slide Table Group (For 9mm)	1	SEE PAGE 6	
	T6-1-20006S	Slide Table Group (For 9mm) (Stainless Steel Model)	1	SEE PAGE 6	
	T6-1-20007	Slide Table Group (For 15.5mm)	1	SEE PAGE 6	
	T6-1-20007S	Slide Table Group (For 15.5mm) (Stainless Steel Model)	1	SEE PAGE 6	
	3	T6-1-30000	Press Group	1	SEE PAGE 12
		T6-1-30000S	Press Group (Stainless Steel Model)	1	SEE PAGE 12
4	T6-1-40000	Heater Group	1	SEE PAGE 17	
5	T6-1-50000	Strapping Head Group	1	SEE PAGE 20	
6	T6-1-60000	Tension Group	1	SEE PAGE 22	
	T6-1-60000S	Tension Group (Stainless Steel Model)	1	SEE PAGE 22	
7	T6-1-70010	Feed Group (For 12mm)	1	SEE PAGE 29	
	T6-1-70010S	Feed Group (For 12mm) (Stainless Steel Model)	1	SEE PAGE 29	
	T6-1-70011	Feed Group (For 9mm)	1	SEE PAGE 29	
	T6-1-70011S	Feed Group (For 9mm) (Stainless Steel Model)	1	SEE PAGE 29	
	T6-1-70012	Feed Group (For 15.5mm)	1	SEE PAGE 29	
	T6-1-70012S	Feed Group (For 15.5mm) (Stainless Steel Model)	1	SEE PAGE 29	

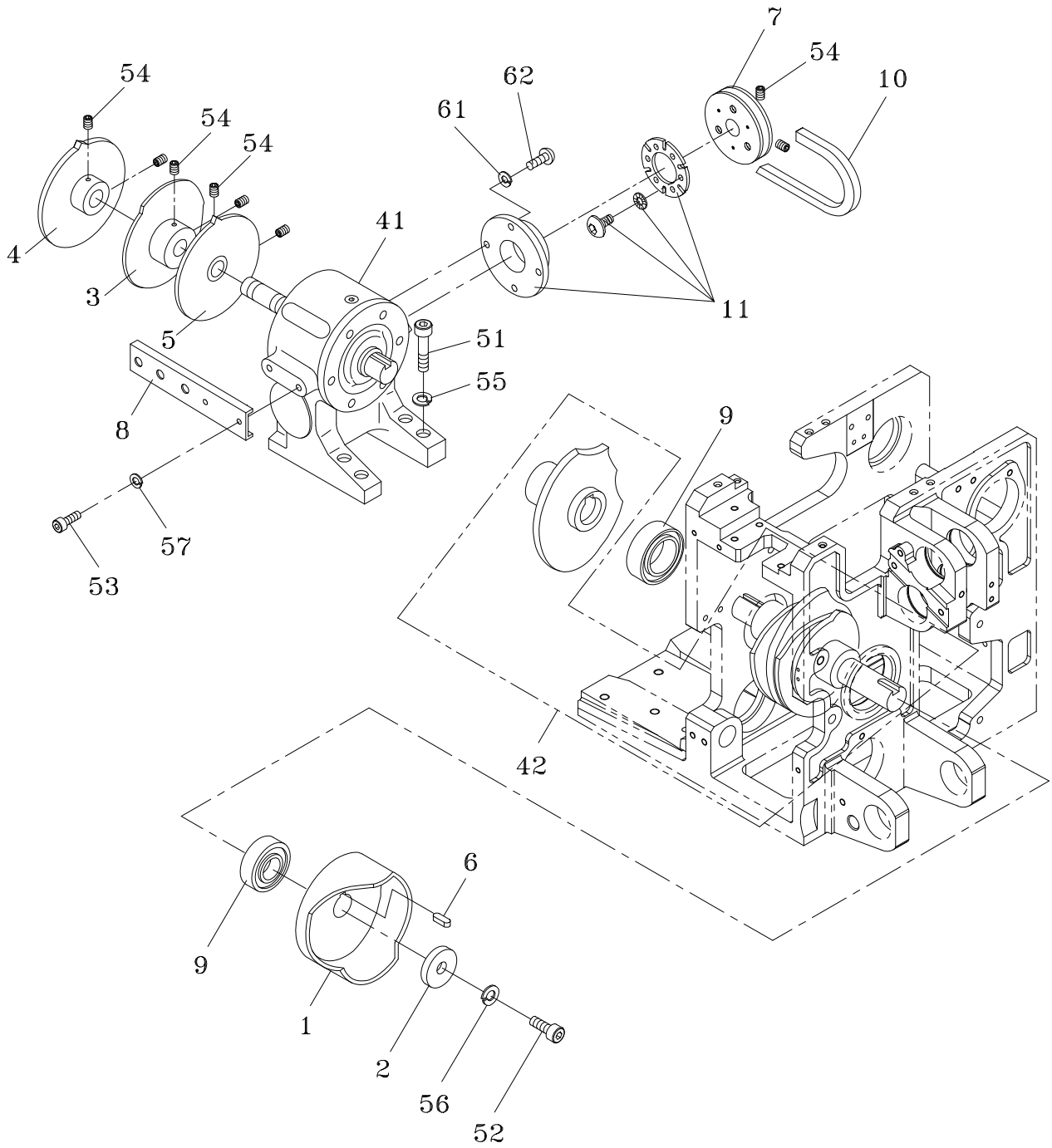

1-1**CAM GROUP****T6-1-10006****T6-1-10007**

REF. NO.	PART NO.	DESCRIPTION	Q'TY	REMARKS
	T6-1-10006	Cam Group (For 1PH)	1	
	T6-1-10007	Cam Group (For 3PH)	1	
1	T6-1-10110	Tension Cam	1	
2	T6-1-10120	Cam Shaft End Plate	1	
3	T6-1-10130	Limit Cam (LS1)	1	
4	T6-1-10140	Limit Switch Contactor A (LS3)	1	
5	T6-1-10150	Limit Switch Contactor B (LS2)	1	
6	KYA070720	Key, 7x7x20	2	
7	T6-6-30004	Gear Box Pulley	1	
8	T6-1-10180	Limit Switch Bracket	1	
9	BR6205ZZ	Bearing, 6205ZZ	2	
10	T6-1-10200	V-Belt (A26) (For 1PH)	1	
	T6-1-10201	V-Belt (A25) (For 3PH)	1	
11	T6-6-10180	Magnet Brake	1	
41	T6-1-11000	Gear Box	1	
42	T6-1-12000	Cam Ass'y	1	SEE PAGE 5
51	HBS0845H	HBS, M8x45 (H)	4	
52	HBS0825	HBS, M8x25	1	
53	HBS0612	HBS, M6x12	2	
54	HSS0610G	HSS, M6x10 (G)	8	
55	PW08B	PW, M8 (B)	4	
56	SW08	SW, M8	1	
57	SW06	SW, M6	2	
61	SW04	SW, M4	4	
62	PMS0408	PMS, M4x8	4	

1-1-1

CAM ASS'Y

T6-1-12000

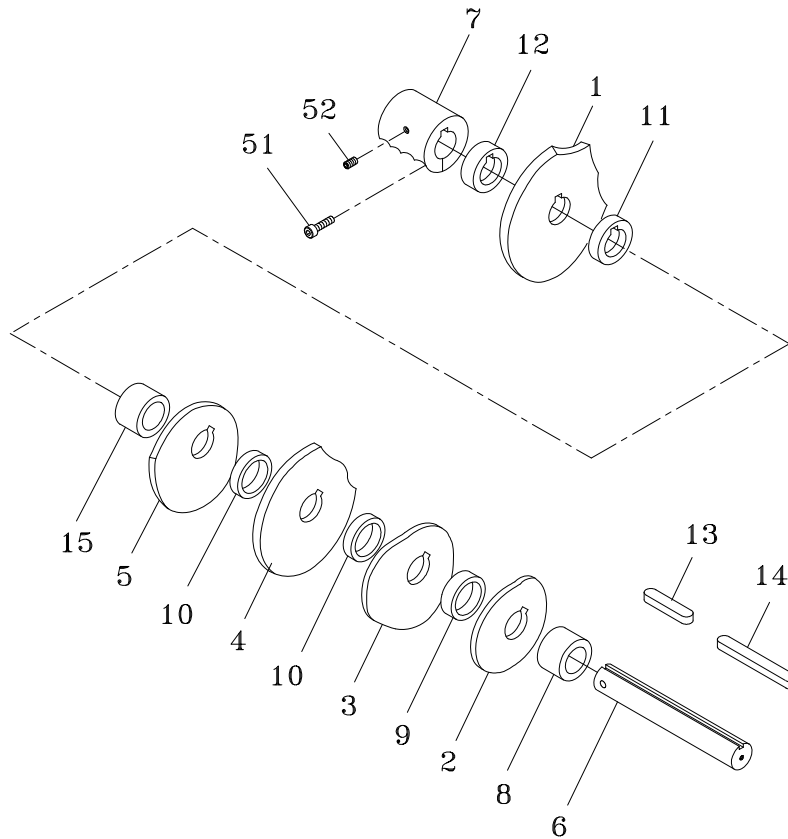

REF. NO.	PART NO.	DESCRIPTION	Q'TY	REMARKS
1	T6-1-12110	Slide Table Cam	1	
2	T6-1-12120	RH Press Cam	1	
3	T6-1-12130	Center Press Cam	1	
4	T6-1-12140	Heater Cam	1	
5	T6-1-12150	LH Press Cam	1	
6	T6-1-12160	Cam Shaft	1	
7	T6-1-12170	Cam Shaft Coupling	1	
8	T6-1-12180	Collar (27.8L)	1	
9	T6-1-12190	Collar (20L)	1	
10	T6-1-12210	Collar(8L)	2	
11	T6-1-12220	Collar (5.5L)	1	
12	T6-1-12230	Collar (14L)	1	
13	KYA070750	Key, 7x7x50	1	
14	KYA070790	Key, 7x7x90	1	
15	T6-1-12350	Collar (28.3L)	1	
51	HBS0620	HBS, M6x20	4	
52	HSS0810G	HSS, M8x10 (G)	1	

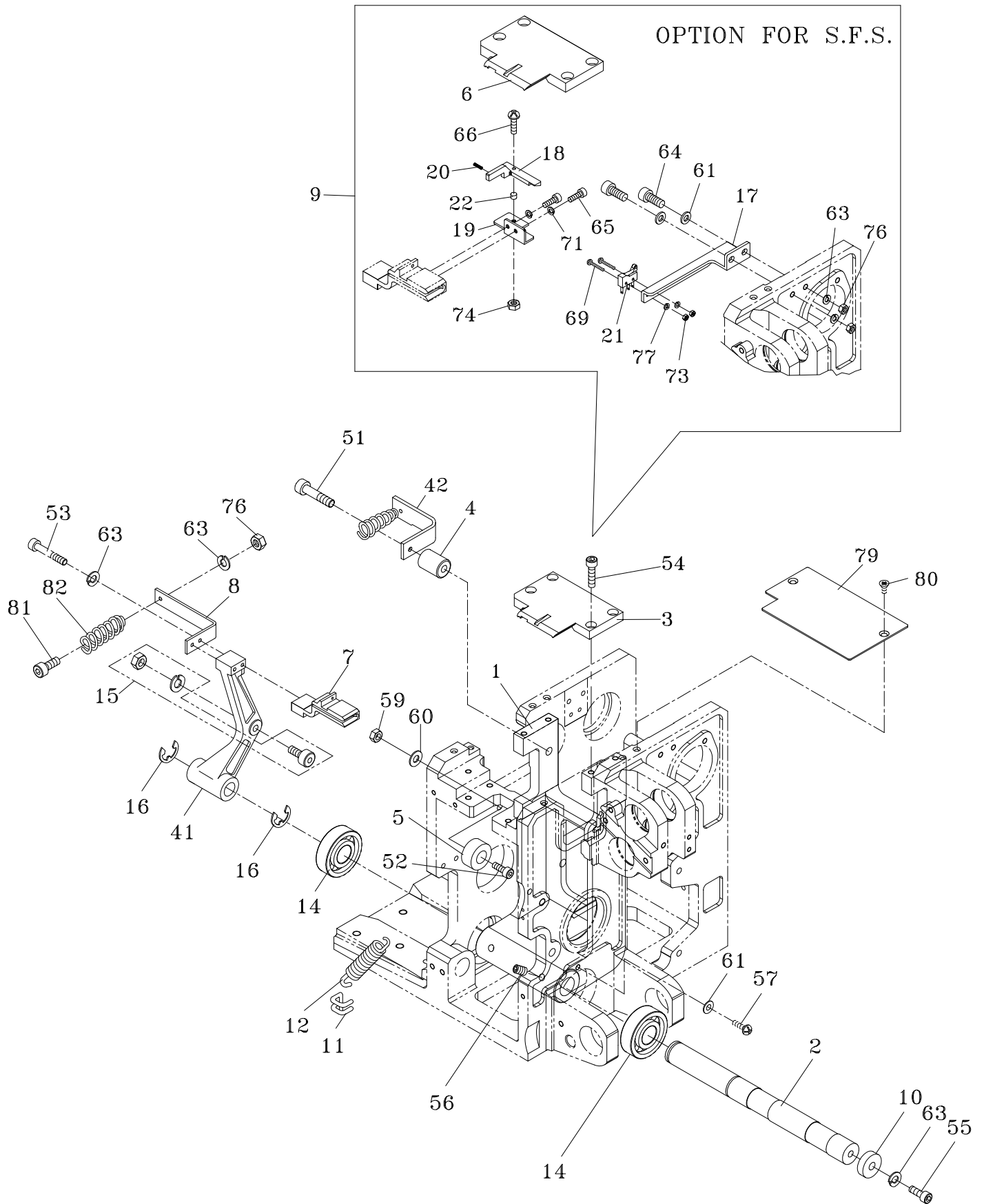

1-2**SLIDE TABLE GROUP****T6-1-20005****T6-1-20006**

REF. NO.	PART NO.	DESCRIPTION	Q'TY	REMARKS
	T6-1-20005	Slide Table Group (For 12mm)	1	
	T6-1-20005S	Slide Table Group (For 12mm) (Stainless Steel Model)	1	
	T6-1-20006	Slide Table Group (For 9mm)	1	
	T6-1-20006S	Slide Table Group (For 9mm) (Stainless Steel Model)	1	
	T6-1-20007	Slide Table Group (For 15.5mm)	1	
	T6-1-20007S	Slide Table Group (For 15.5mm) (Stainless Steel Model)	1	
1	T6-1-20110	Slide Table Frame	1	
2	T6-1-20120	Slide Table Frame Shaft	1	
3	T6-1-20130	Slide Table (For 12mm)	1	
	T6-1-20130S1	Slide Table (For 12mm)(Stainless Steel Model)	1	
	T6-1-20133	Slide Table (For 9mm)	1	
	T6-1-20133S1	Slide Table (For 9mm)(Stainless Steel Model)	1	
	T6-1-20132	Slide Table (For 15.5mm)	1	
	T6-1-20132S1	Slide Table (For 15.5mm) (Stainless Steel Model)	1	
4	T6-1-20140	Slide Table Back Adjusting	1	
5	T6-1-20150	Slide Table Stopper	1	
6	T6-1-20160	Slide Table (For S.F.S, 12mm)(Option)	1	
	T6-1-20160S1	Slide Table (For S.F.S, 12mm) (Stainless Steel Model)(Option)	1	
	T6-1-20161	Slide Table (For S.F.S, 9mm)(Option)	1	
	T6-1-20161S1	Slide Table (For S.F.S, 9mm) (Stainless Steel Model)(Option)	1	
	T6-1-20162	Slide Table (For S.F.S, 15.5mm) (Option)	1	
	T6-1-20162S1	Slide Table (For S.F.S, 15.5mm) (Stainless Steel Model)(Option)	1	
7	T6-1-20170	Strap Guide (For 12mm/9mm)	1	
	T6-1-20172	Strap Guide (For 15.5mm)	1	
8	T6-1-20180	Flap Connecting Spring Bracket	1	

REF. NO.	PART NO.	DESCRIPTION	Q'TY	REMARKS
9	T6-1-20194	S.F.S Ass'y (For S.F.S, 12mm)(Option)	1	
	T6-1-20194S	S.F.S Ass'y (For S.F.S, 12mm) (Stainless Steel Model)(Option)	1	
	T6-1-20191	S.F.S Ass'y (For S.F.S, 9mm)(Option)	1	
	T6-1-20191S	S.F.S Ass'y (For S.F.S, 9mm) (Stainless Steel Model)(Option)	1	
	T6-1-20192	S.F.S Ass'y (For S.F.S, 15.5mm) (Option)	1	
	T6-1-20192S	S.F.S Ass'y (For S.F.S, 15.5mm) (Stainless Steel Model)(Option)	1	
10	T6-1-30170	End Plate	1	
11	T6-1-20220	Slide Table Spring Hook	1	
12	T6-1-20230	Slide Table Tension Spring	1	
14	BR6304ZZ	Bearing, 6304ZZ	2	
15	T6-1-20250	Cam Follower, KR22xLL	1	
16	ER15	Snap Ring, E-15	2	
17	T6-1-20310	Support (For S.F.S)(Option)	1	
18	T6-1-20322	Lever (For S.F.S)(Option)	1	
19	T6-1-20340	Bracket (For S.F.S)(Option)	1	
20	T6-1-20351	Spring (For S.F.S)(Option)	1	
21	T6-1-20360	Limit Switch (For S.F.S)(Option)	1	
22	T6-1-20450	Bush (For S.F.S)(Option)	1	
41	T6-1-21000	Strap Guide Arm Ass'y	1	SEE PAGE 10
42	T6-1-22000	Strap Guide Spring Ass'y	1	SEE PAGE 11
51	HBS1050H	HBS, M10x50 (H)	1	
52	HBS0830	HBS, M8x30	1	
53	HBS0650H	HBS, M6x50 (H)	1	
54	HBS0620N	HBS, M6x20 (N)	4	
	HBS0620S	HBS, M6x20 (Stainless Steel Model)	4	
55	HBS0625	HBS, M6x25	1	
56	HSS0810G	HSS, M8x10 (G)	4	
57	TMS0610	TMS, M6x10	2	
59	HN08	HN, M8	1	

REF. NO.	PART NO.	DESCRIPTION	Q'TY	REMARKS
60	PW08A	PW, M8 (A)	1	
61	PW06A	PW, M6 (A)	2	
		PW, M6 (A)(For S.F.S)(Option)	4	
63	SW06	SW, M6	4	
		SW, M6 (For S.F.S)(Option)	6	
64	HBS0620	HBS, M6x20 (For S.F.S)(Option)	2	
65	HBS0408	HBS, M4x8 (For S.F.S)(Option)	2	
66	TMS0412	TMS, M4x12 (For S.F.S)(Option)	1	
69	PMS0212	PMS, M2x12 (For S.F.S)(Option)	2	
71	SW04	SW, M4 (For S.F.S)(Option)	2	
73	HN02	HN, M2 (For S.F.S)(Option)	2	
74	NTE04	NTE, M4 (For S.F.S)(Option)	1	
76	HN06	HN, M6	1	
		HN, M6 (For S.F.S)(Option)	3	
77	SW02	SW, M2 (For S.F.S)(Option)	2	
79	T6-1-20890	Cover	1	
	T6-1-20890S	Cover (Stainless Steel Model)	1	
80	FMS0510	FMS, M5x10	2	
	FMS0510S	FMS, M5x10 (Stainless Steel Model)	2	
81	HBS0616	HBS, M6x16	1	
82	T6-2-10130	LH Bandway Stop Spring	1	

1-2-1

STRAP GUIDE ARM ASS'Y

T6-1-21000

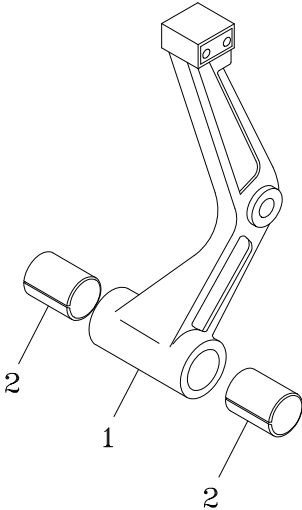

REF. NO.	PART NO.	DESCRIPTION	Q'TY	REMARKS
1	T6-1-21110	Strap Guide Arm	1	
2	MB2025	Metal Bushing, 2025	2	

1-2-2

STRAP GUIDE SPRING ASS'Y

T6-1-22000

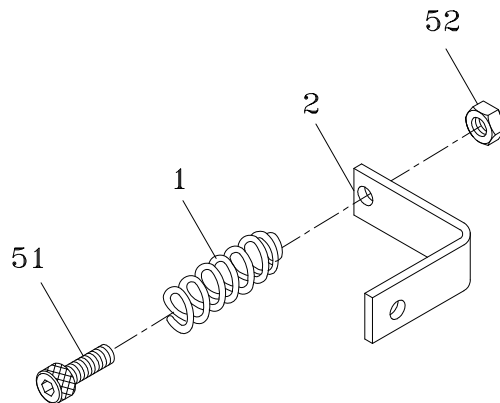

REF. NO.	PART NO.	DESCRIPTION	Q'TY	REMARKS
1	T6-1-22110	Strap Guide Spring	1	
2	T6-1-22120	Strap Guide Spring Bracket	1	
51	HBS0616	HBS, M6x16	1	
52	HN06	HN, M6	1	

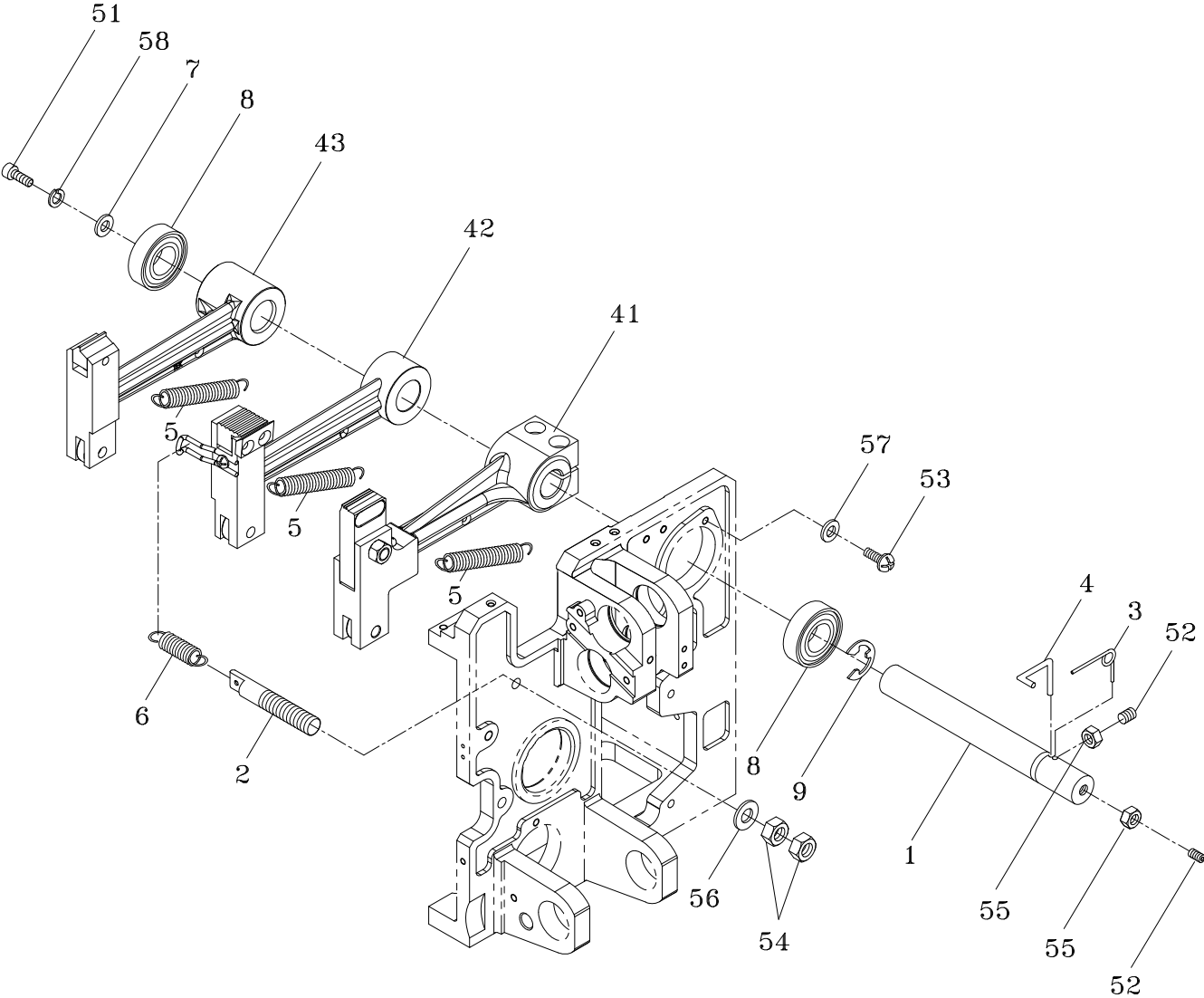

1-3

PRESS GROUP

T6-1-30000

REF. NO.	PART NO.	DESCRIPTION	Q'TY	REMARKS
	T6-1-30000	Press Group	1	
	T6-1-30000S	Press Group (Stainless Steel Model)	1	
1	T6-1-30110	Press Arm Shaft	1	
2	T6-1-30120	Cutter Tension Spring Hook	1	
3	T6-1-30130	Upper Roller Spring	1	
4	T6-1-30140	Upper Shaft Spring Adjuster	1	
5	T6-1-30150	Press Tension Spring	3	
6	T6-1-30160	Cutter Tension Spring	1	
7	T6-1-30170	Press Arm End Plate	1	
8	BR6304ZZ	Bearing, 6304ZZ	2	
9	ER15	Snap Ring, E-15	1	
41	T6-1-31000	RH, Block Arm Ass'y	1	SEE PAGE 14
	T6-1-31000S	RH, Block Arm Ass'y (Stainless Steel Model)	1	SEE PAGE 14
42	T6-1-32000	Center Block Arm Ass'y	1	SEE PAGE 15
	T6-1-32000S	Center Block Arm Ass'y (Stainless Steel Model)	1	SEE PAGE 15
43	T6-1-33000	LH, Block Arm Ass'y	1	SEE PAGE 16
51	HBS0620	HBS, M6x20	1	
52	HSS0615G	HSS, M6x15 (G)	2	
53	TMS0610	TMS, M6x10	2	
54	HN08	HN, M8	2	
55	HN06	HN, M6	2	
56	PW08A	PW, M8 (A)	1	
57	PW06B	PW, M6 (B)	2	
58	SW06	SW, M6	1	

1-3-1

RH, BLOCK ARM ASS'Y

T6-1-31000

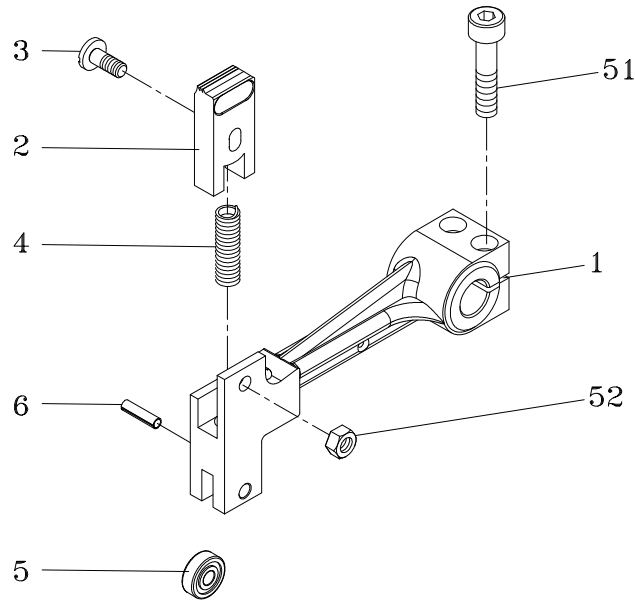

REF. NO.	PART NO.	DESCRIPTION	Q'TY	REMARKS
	T6-1-31000	RH, Block Arm Ass'y	1	
	T6-1-31000S	RH, Block Arm Ass'y (Stainless Steel Model)	1	
1	T6-1-31110	RH, Block Arm	1	
2	T6-1-31120	Upper Cutter	1	
	T6-1-31120S	Upper Cutter (Stainless Steel Model)	1	
3	T6-1-31130	Upper Cutter Pin	1	
4	T6-1-31140	RH, Block Spring	1	
5	BR628ZZ	Bearing, 628ZZ	1	
6	SP0824	Spring Pin, 8x24	1	
51	HBS0835H	HBS, M8x35 (H)	2	
52	HN10	HN, M10	1	

1-3-2

CENTER BLOCK ARM ASS'Y T6-1-32000

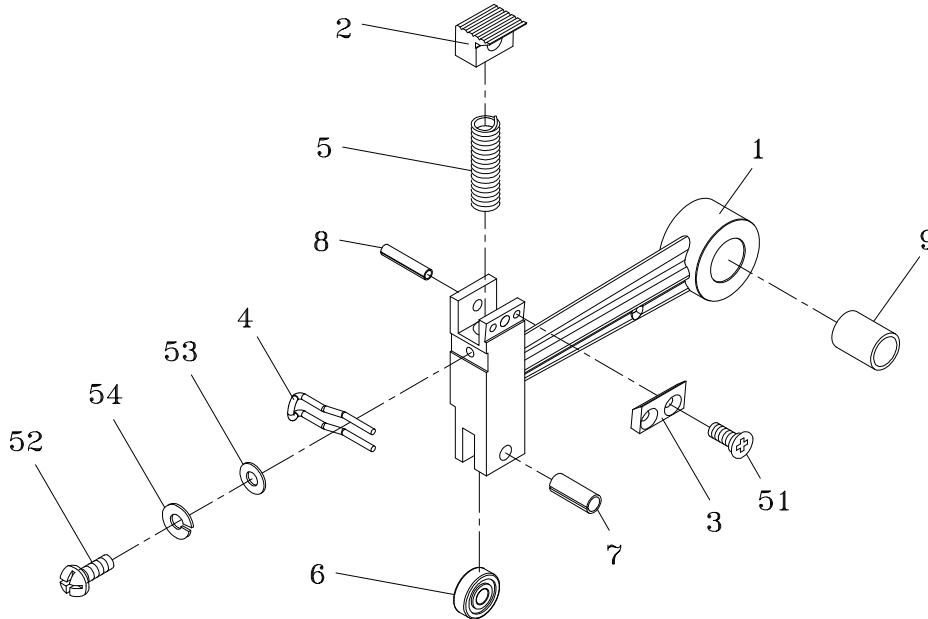

REF. NO.	PART NO.	DESCRIPTION	Q'TY	REMARKS
	T6-1-32000	Center Block Arm Ass'y	1	
	T6-1-32000S	Center Block Arm Ass'y (Stainless Steel Model)	1	
1	T6-1-32110	Center Block Arm	1	
2	T6-1-32120	Universal Press	1	
	T6-1-32120S	Universal Press (Stainless Steel Model)	1	
3	T6-1-32130	Lower Cutter	1	
	T6-1-32130S	Lower Cutter (Stainless Steel Model)	1	
4	T6-1-32140	Cutter Spring Hook	1	
5	T6-1-32150	LH & Center Block Spring	1	
6	BR628ZZ	Bearing, 628ZZ	1	
7	SP0820	Spring Pin, 8x20	1	
8	SP0622	Spring Pin, 6x22	1	
9	MB2025	Metal Bushing, 2025	1	
51	FMS0510S	FMS, M5x10 (SUS)	2	
52	PMS0610	PMS, M6x10	1	
53	PW06A	PW, M6 (A)	1	
54	SW06	SW, M6	1	

1-3-3

LH, BLOCK ARM ASS'Y T6-1-33000

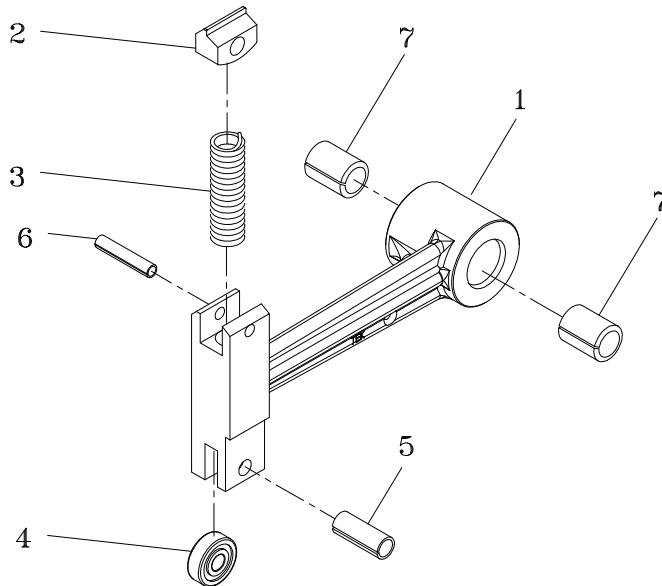

REF. NO.	PART NO.	DESCRIPTION	Q'TY	REMARKS
1	T6-1-33110	LH, Block Arm	1	
2	T6-1-33120	Jaw Left	1	
3	T6-1-32150	LH & Center Block Spring	1	
4	BR628ZZ	Bearing, 628ZZ	1	
5	SP0820	Spring Pin, 8x20	1	
6	SP0622	Spring Pin, 6x22	1	
7	MB2020	Metal Bushing, 2020	2	

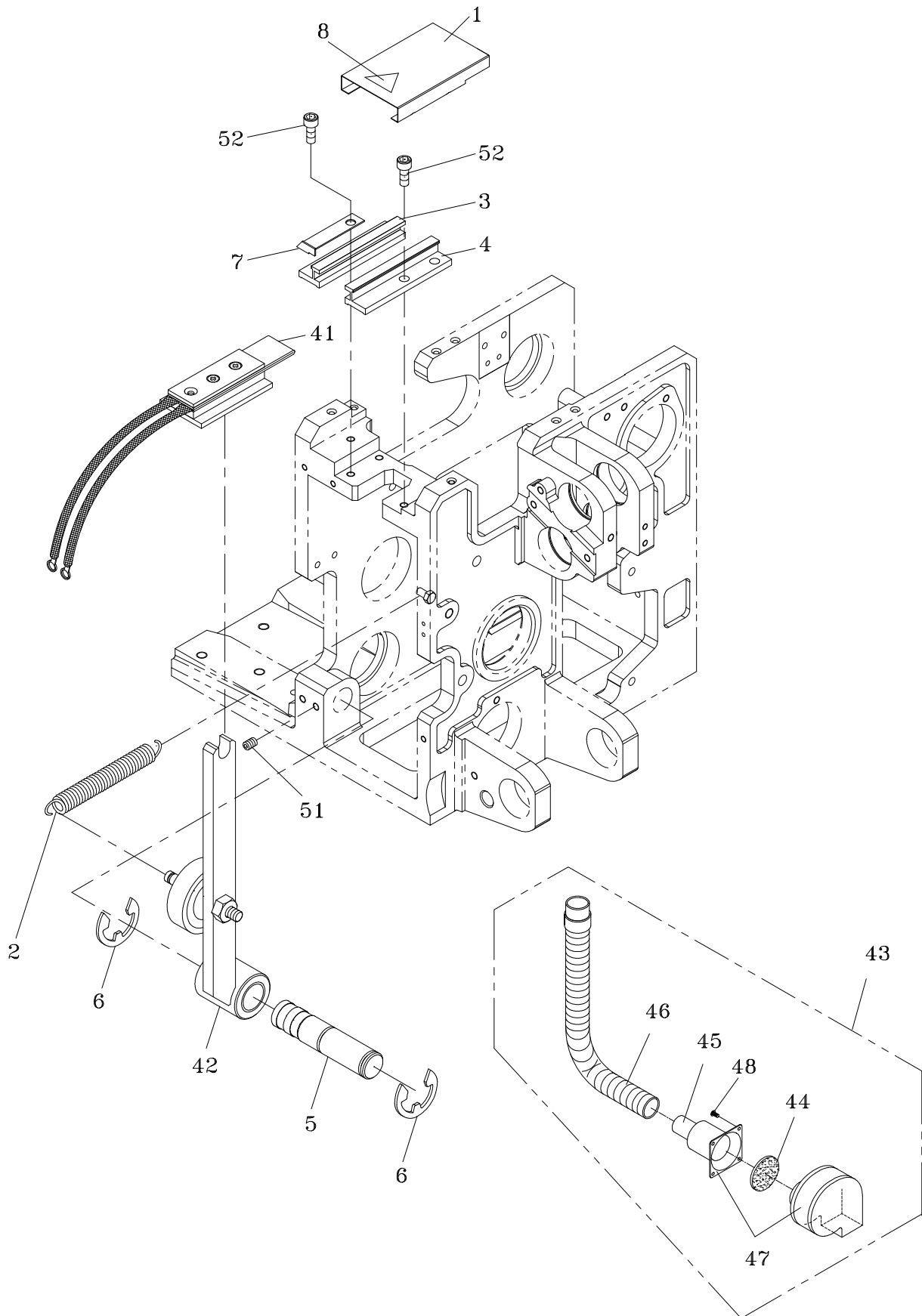

1-4**HEATER GROUP****T6-1-40000**

REF. NO.	PART NO.	DESCRIPTION	Q'TY	REMARKS
1	T6-1-40110	Heater Cover	1	
2	T6-1-40120	Heater Crank Spring	1	
3	T6-1-40130	Heater Slider Guide (L)	1	
4	T6-1-40140	Heater Slider Guide (R)	1	
5	T6-1-40150	Heater Crank Shaft	1	
6	ER15	Snap Ring, E-15	2	
7	T6-1-40170	Heater Stopper	1	
8	LA-40002	Label	1	
41	T6-1-41000	Heater Ass'y	1	
42	T6-1-42000	Heater Crank Ass'y	1	SEE PAGE 19
43	T6-1-43000	Smoke-exhaustion system, with active carbon filter. (Option)	1	
	T6-1-43001	Smoke-exhaustion system, without active carbon filter. (Option)	1	
44	T6-6-10920	Active Carbon Filter (Option)	1	
45	T6-6-10930	Nipple (Option)	1	
46	T6-6-10940	Smoke-Exhaustion Pipe (Option)	1	
47	T6-6-10970	Fan (For Smoke)(Option)	1	
48	TMS0408	TMS, M4x8 (Option)	4	
51	HSS0610G	HSS, M6x10 (G)	2	
52	HBS0616	HBS, M6x16	4	

1-4-1

HEATER CRANK ASS'Y

T6-1-42000

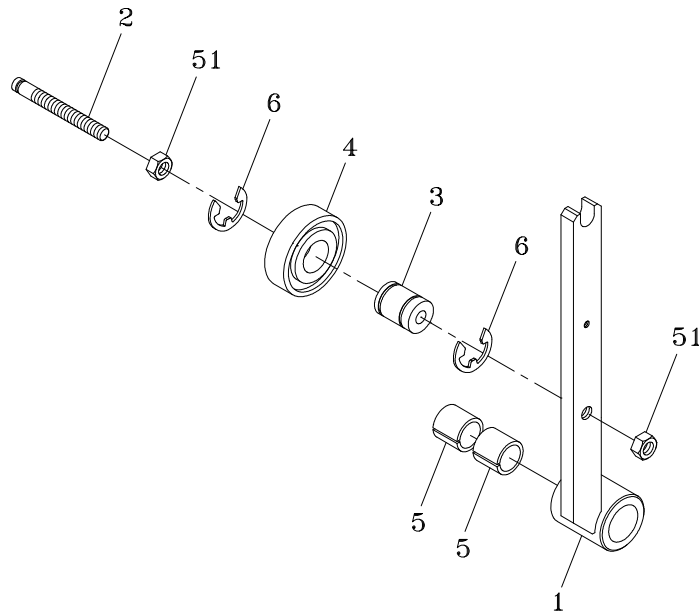

REF. NO.	PART NO.	DESCRIPTION	Q'TY	REMARKS
1	T6-1-42110	Heater Crank	1	
2	T6-1-42120	Heater Bearing Shaft	1	
3	T6-1-42130	Heater Crank Collar	1	
4	BR6304ZZ	Bearing, 6304ZZ	1	
5	MB2015	Metal Bushing, 2015	2	
6	ER15	Snap Ring, E-15	2	
51	HN08	HN, M8	2	

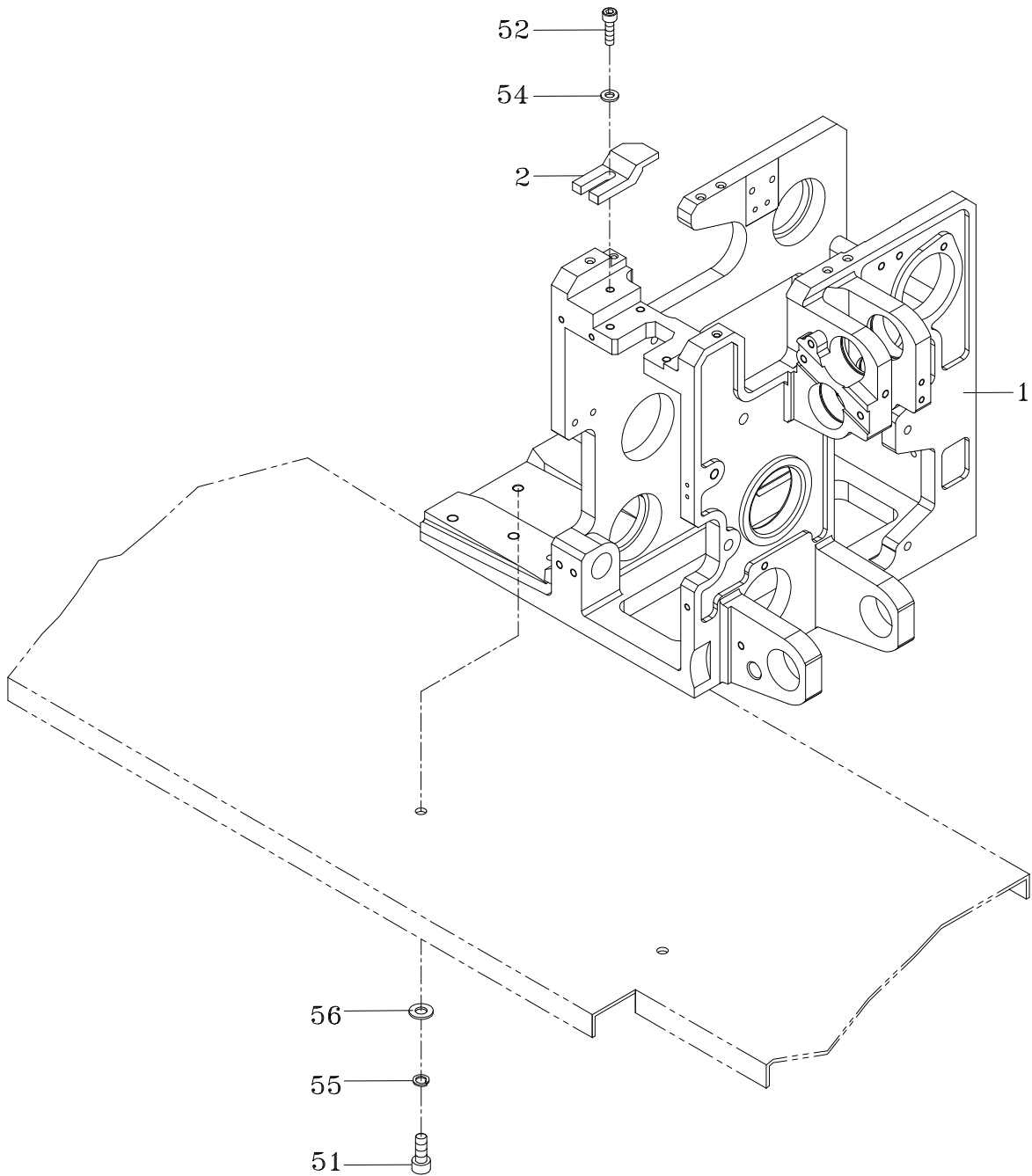

1-5**STRAPPING HEAD GROUP****T6-1-50000**

REF. NO.	PART NO.	DESCRIPTION	Q'TY	REMARKS
1	T6-1-50100	Strapping Head Frame	1	
2	T6-1-50111	Band Width Block	1	
51	HBS0820	HBS, M8x20	4	
52	HBS0620	HBS, M6x20	1	
54	PW06B	PW, M6 (B)	1	
55	SW08	SW, M8	4	
56	PW08C	PW, M8 (C)	4	

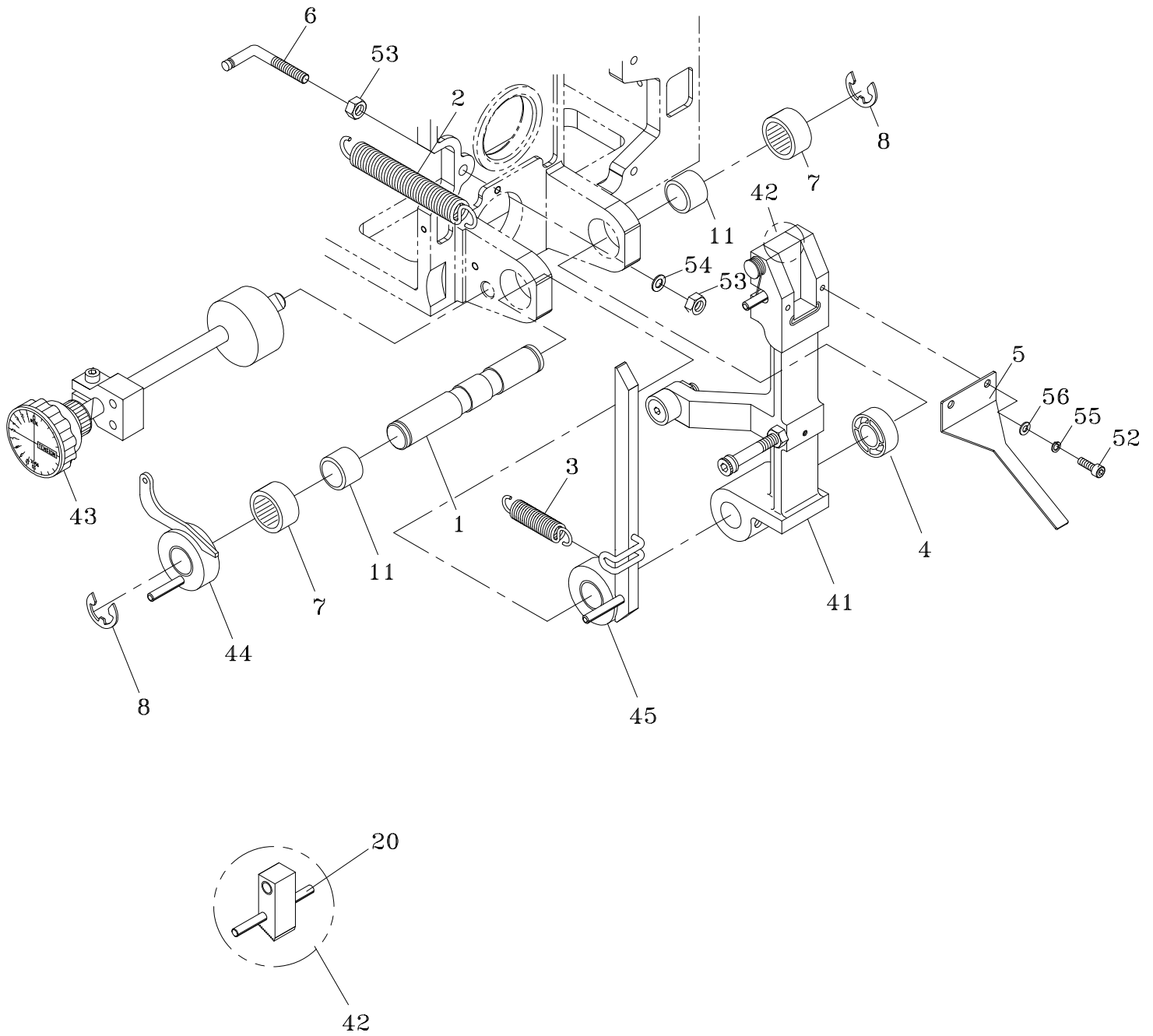

1-6**TENSION GROUP****T6-1-60000**

REF. NO.	PART NO.	DESCRIPTION	Q'TY	REMARKS
	T6-1-60000	Tension Group	1	
	T6-1-60000S	Tension Group (Stainless Steel Model)	1	
1	T6-1-60110	Tension Arm Shaft	1	
2	T6-1-60120	Tension Arm Spring	1	
3	T6-1-60130	Tension Adjusting Arm Spring	1	
4	T6-1-60140	Tension Arm Spacer	1	
5	T6-1-60150	Strap Cover	1	
6	T6-1-60160	Tension Arm Spring Hook L-Type	1	
7	BRHK2516	Bearing, HK2516	2	
8	ER15	Snap Ring, E-15	2	
11	BRIR202517	Bearing, IR202517	2	
20	SP0680	Spring Pin, 6x80	1	
41	T6-1-61000	Tension Arm Ass'y	1	SEE PAGE 24
42	T6-1-62000	Tension Jaw Ass'y	1	
	T6-1-62000S	Tension Jaw Ass'y (Stainless Steel Model)	1	
43	T6-1-63001	Tension Adjusting Cam Ass'y	1	SEE PAGE 25
	T6-1-63001S	Tension Adjusting Cam Ass'y (Stainless Steel Model)	1	SEE PAGE 25
44	T6-1-64000	Tension Adjusting Ass'y	1	SEE PAGE 27
45	T6-1-65000	Tension Adjusting Arm Ass'y	1	SEE PAGE 28
52	HBS0512	HBS, M5x12	2	
53	HN08	HN, M8	2	
54	PW08B	PW, M8 (B)	1	
55	SW05	SW, M5	2	
56	PW05	PW, M5	2	

1-6-1

TENSION ARM ASS'Y

T6-1-61000

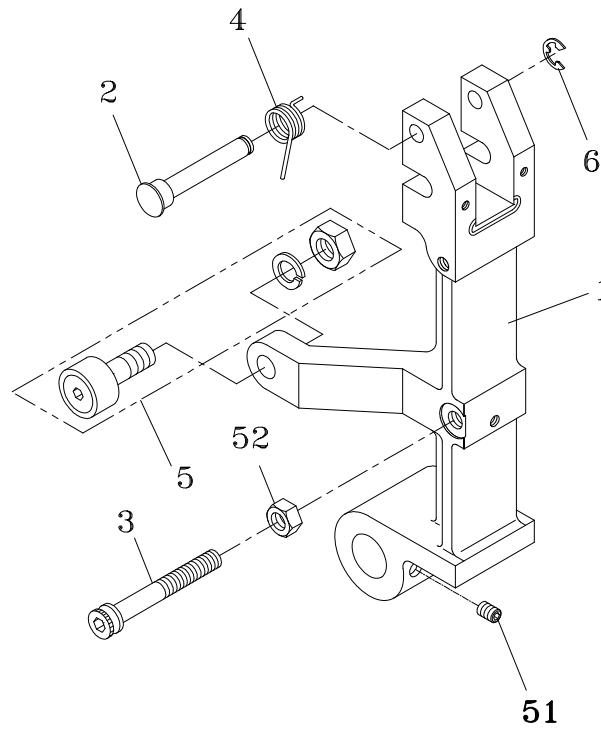

REF. NO.	PART NO.	DESCRIPTION	Q'TY	REMARKS
1	T6-1-61110	Tension Arm	1	
2	T6-1-61120	Tension Jaw Shaft	1	
3	T6-1-61130	Tension Arm Spring Hook I-Type	1	
4	T6-1-61140	Tension Jaw Spring	1	
5	T6-1-20250	Cam Follower, KR22xLL	1	
6	ER06	Snap Ring, E-6	1	
51	HSS0810G	HSS, M8x10 (G)	2	
52	HN08	HN, M8	1	

1-6-3 TENSION ADJUSTING CAM ASS'Y T6-1-63001

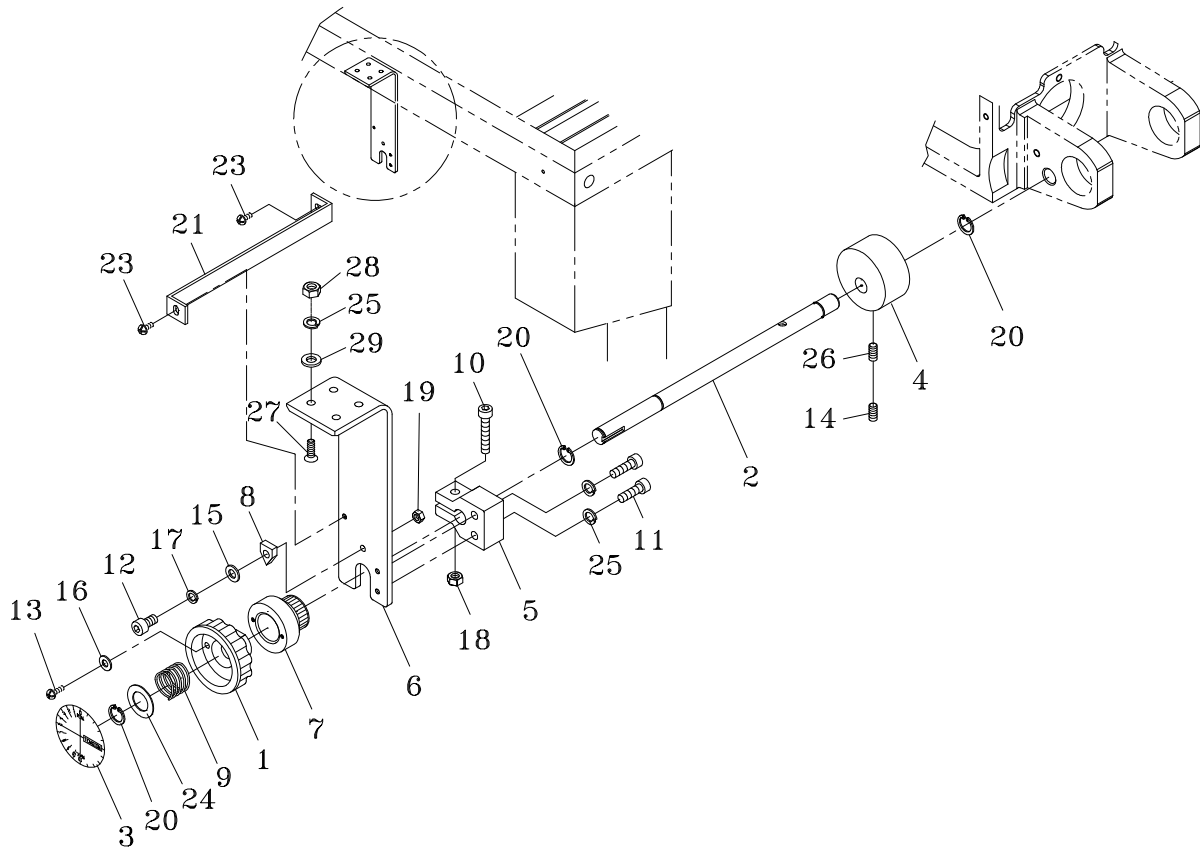

REF. NO.	PART NO.	DESCRIPTION	Q'TY	REMARKS
	T6-1-63001	Tension Adjusting Cam Ass'y	1	
	T6-1-63001S	Tension Adjusting Cam Ass'y (Stainless Steel Model)	1	
1	T6-1-63011	Tension Adjusting Handle	1	
2	T6-1-63012	Tension Adjusting Shaft	1	
3	T6-1-63130	Plate (Tension Selector Knob)	1	
4	T6-1-63014	Tension Adjusting Cam	1	
5	T6-1-63015	Bushing	1	
6	T6-1-63016	Support	1	
	T6-1-63016S	Support (Stainless Steel Model)	1	
7	T6-1-63017	Stopper	1	
8	T6-1-63018	Tension Adjusting Cam Lock	1	
9	T6-1-63019	Spring	1	

1-6-3

TENSION ADJUSTING CAM ASS'Y

T6-1-63001

REF. NO.	PART NO.	DESCRIPTION	Q'TY	REMARKS
10	HBS0625	HBS, M6x25	1	
11	HBS0620	HBS, M6x20	2	
12	HBS0516	HBS, M5x16	1	
13	PMS0412	PMS, M4x12	2	
14	HSS0608G	HSS, M6x8 (G)	1	
15	PW05	PW, M5	1	
16	PW04	PW, M4	2	
17	SW05	SW, M5	1	
18	NTE06	NTE, M6	1	
19	HN05	HN, M5	1	
20	SR12	Stop Ring, S-12	3	
21	T6-1-63031	Bracket	1	
	T6-1-63031S	Bracket (Stainless Steel Model)	1	
23	TMS0508	TMS, M5x8	2	
24	T6-1-63034	Washer	1	
25	SW06	SW, M6	6	
26	HBS0610	HBS, M6x10	1	
27	FMS0620S	FMS, M6x20 (SUS)	4	
28	HN06	HN, M6	4	
29	PW06A	PW, M6 (A)	4	

1-6-4

TENSION ADJUSTING ASS'Y T6-1-64000

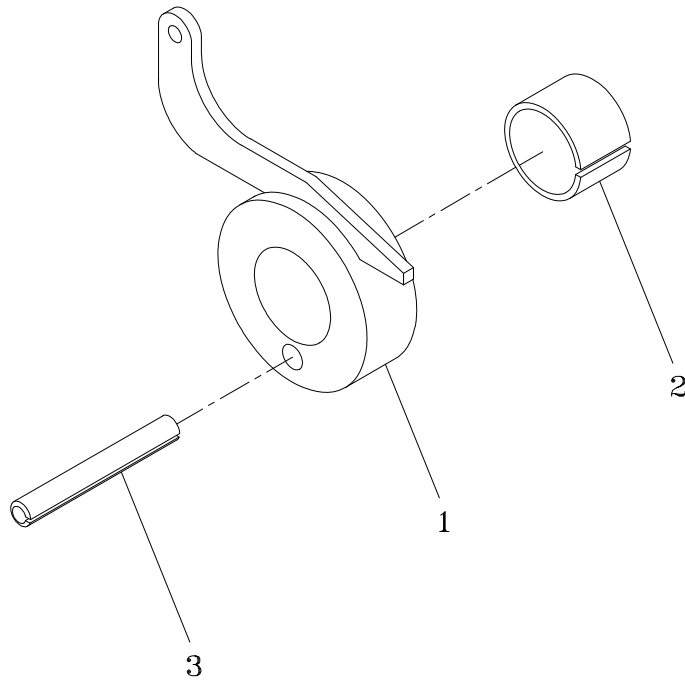

REF. NO.	PART NO.	DESCRIPTION	Q'TY	REMARKS
1	T6-1-64110	Tension Adjusting	1	
2	MB2015	Metal Bushing, 2015	1	
3	SP0645	Spring Pin, 6x45	1	

1-6-5 TENSION ADJUSTING ARM ASS'Y T6-1-65000

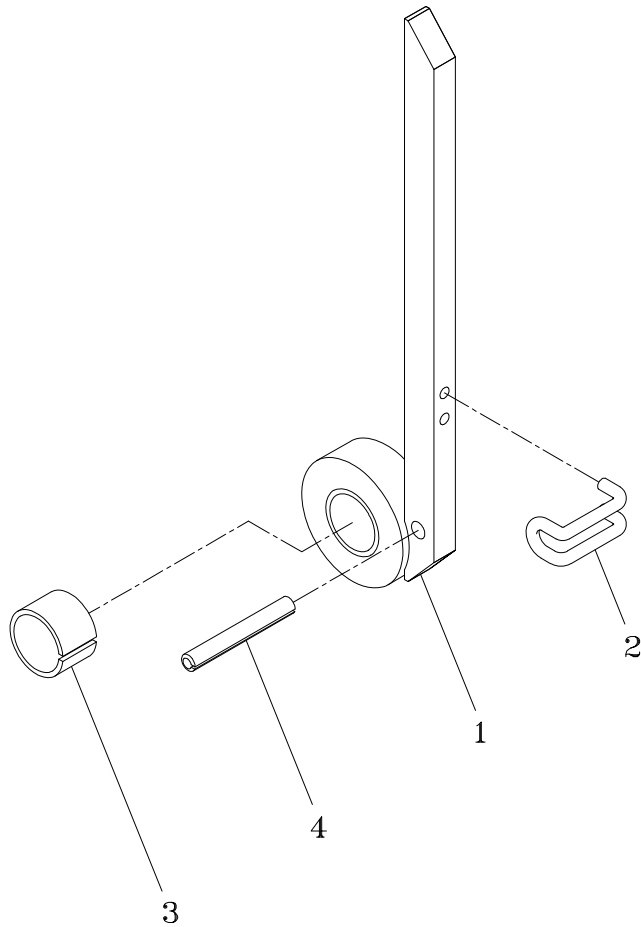

REF. NO.	PART NO.	DESCRIPTIO	Q'TY	REMARKS
1	T6-1-65110	Tension Adjusting Arm	1	
2	T6-1-65120	Tension Adjusting Arm Spring Hook	1	
3	MB2015	Metal Bushing, 2015	1	
4	SP0645	Spring Pin, 6x45	1	

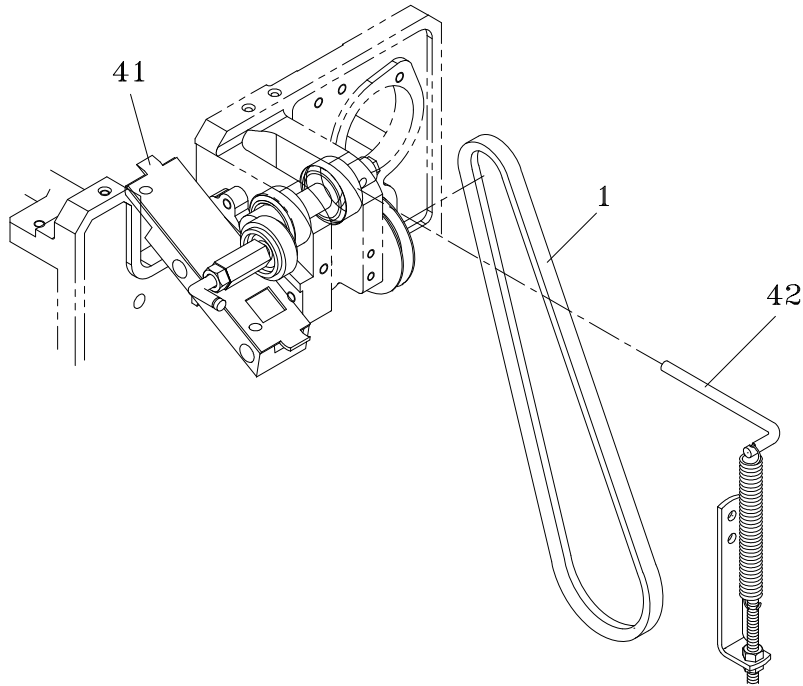

REF. NO.	PART NO.	DESCRIPTION	Q'TY	REMARKS
	T6-1-70010	Feed Group (For 12mm)	1	
	T6-1-70010S	Feed Group (For 12mm) (Stainless Steel Model)	1	
	T6-1-70011	Feed Group (For 9mm)	1	
	T6-1-70011S	Feed Group (For 9mm) (Stainless Steel Model)	1	
	T6-1-70012	Feed Group (For 15.5mm)	1	
	T6-1-70012S	Feed Group (For 15.5mm) (Stainless Steel Model)	1	
1	T6-1-70110	V-Belt M-21	1	
41	T6-1-71000	Feed Ass'y (For 12mm)	1	SEE PAGE 30
	T6-1-71000S	Feed Ass'y (For 12mm) (Stainless Steel Model)	1	SEE PAGE 30
	T6-1-71004	Feed Ass'y (For 9mm)	1	SEE PAGE 30
	T6-1-71004S	Feed Ass'y (For 9mm) (Stainless Steel Model)	1	SEE PAGE 30
	T6-1-71005	Feed Ass'y (For 15.5mm)	1	SEE PAGE 30
	T6-1-71005S	Feed Ass'y (For 15.5mm) (Stainless Steel Model)	1	SEE PAGE 30
42	T6-1-72000	Upper Adjusting Weight Ass'y	1	SEE PAGE 33

1-7-1

FEED ASS'Y

T6-1-71000
T6-1-71004

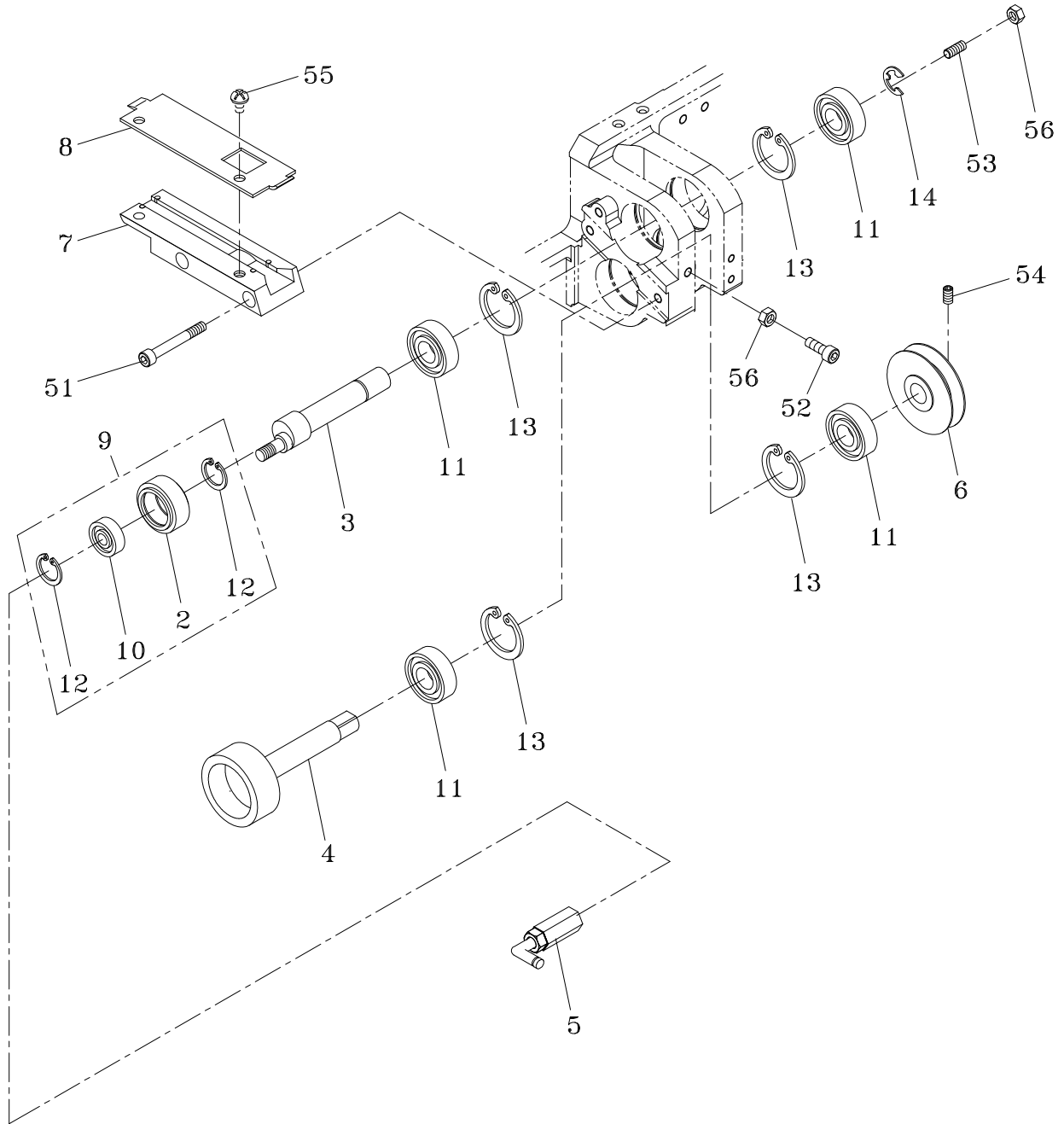

1-7-1**FEED ASS'Y****T6-1-71000****T6-1-71004**

REF. NO.	PART NO.	DESCRIPTION	Q'TY	REMARKS
	T6-1-71000	Feed Ass'y (For 12mm)	1	
	T6-1-71000S	Feed Ass'y (For 12mm) (Stainless Steel Model)	1	
	T6-1-71004	Feed Ass'y (For 9mm)	1	
	T6-1-71004S	Feed Ass'y (For 9mm) (Stainless Steel Model)	1	
	T6-1-71005	Feed Ass'y (For 15.5mm)	1	
	T6-1-71005S	Feed Ass'y (For 15.5mm) (Stainless Steel Model)	1	
2	T6-1-71120	Upper Feed Roller (For 12mm)	1	
	T6-1-71120S	Upper Feed Roller (For 12mm) (Stainless Steel Model)	1	
	T6-1-71121	Upper Feed Roller (For 9mm)	1	
	T6-1-71121S	Upper Feed Roller (For 9mm) (Stainless Steel Model)	1	
	T6-1-71122	Upper Feed Roller (For 15.5mm)	1	
	T6-1-71122S	Upper Feed Roller (For 15.5mm) (Stainless Steel Model)	1	
3	T6-1-71130	Upper Feed Roller Shaft	1	
4	T6-1-71140	Feed Roller	1	
	T6-1-71140S	Feed Roller (Stainless Steel Model)	1	
5	T6-1-71150	Lever Holder	1	
6	T6-1-71160	Feed Roller Pulley	1	
7	T6-1-71170	Feed Shooter (For 12mm)	1	
	T6-1-71170S	Feed Shooter (For 12mm) (Stainless Steel Model)	1	
	T6-1-71171	Feed Shooter (For 9mm)	1	
	T6-1-71171S	Feed Shooter (For 9mm) (Stainless Steel Model)	1	
	T6-1-71172	Feed Shooter (For 15.5mm)	1	
	T6-1-71172S	Feed Shooter (For 15.5mm) (Stainless Steel Model)	1	
8	T6-1-71180	Feed Shooter Cover	1	
	T6-1-71180S	Feed Shooter Cover (Stainless Steel Model)	1	

1-7-1**FEED ASS'Y****T6-1-71000****T6-1-71004**

REF. NO.	PART NO.	DESCRIPTION	Q'TY	REMARKS
9	T6-1-71190	Upper Feed Roller Set (For 12mm)	1	
	T6-1-71190S	Upper Feed Roller Set (For 12mm) (Stainless Steel Model)	1	
	T6-1-71191	Upper Feed Roller Set (For 9mm)	1	
	T6-1-71191S	Upper Feed Roller Set (For 9mm) (Stainless Steel Model)	1	
	T6-1-71192	Upper Feed Roller Set (For 15.5mm)	1	
	T6-1-71192S	Upper Feed Roller Set (For 15.5mm) (Stainless Steel Model)	1	
10	BR628ZZ	Bearing, 628ZZ	1	
11	BR6202ZZ	Bearing, 6202ZZ	4	
12	RR24	Snap Ring, H-24	2	
13	RR35	Snap Ring, H-35	4	
14	ER12	Snap Ring, E-12	1	
51	HBS0645H	HBS, M6x45 (H)	2	
	HBS0645HS	HBS, M6x45 (H)(Stainless Steel Model)	2	
52	HBS0616	HBS, M6x16	1	
53	HSS0615G	HSS, M6x15 (G)	1	
54	HSS0610G	HSS, M6x10 (G)	2	
55	PMS0610	PMS, M6x10	2	
	PMS0610S	PMS, M6x10 (Stainless Steel Model)	2	
56	HN06	HN, M6	2	

1-7-2 UPPER ADJUSTING WEIGHT ASS'Y T6-1-72000

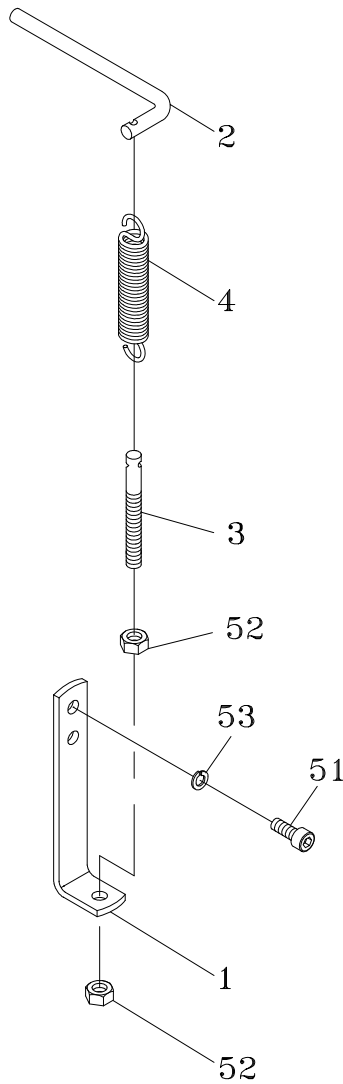

REF. NO.	PART NO.	DESCRIPTION	Q'TY	REMARKS
1	T6-1-72110	Upper Adjusting Base	1	
2	T6-1-72120	Upper Adjusting Spring Hook	1	
3	T6-1-72130	Upper Adjusting Spring Rod	1	
4	T6-1-72140	Spring	1	
51	HBS0512	HBS, M5x12	2	
52	HN06	HN, M6	2	
53	SW05	SW, M5	2	

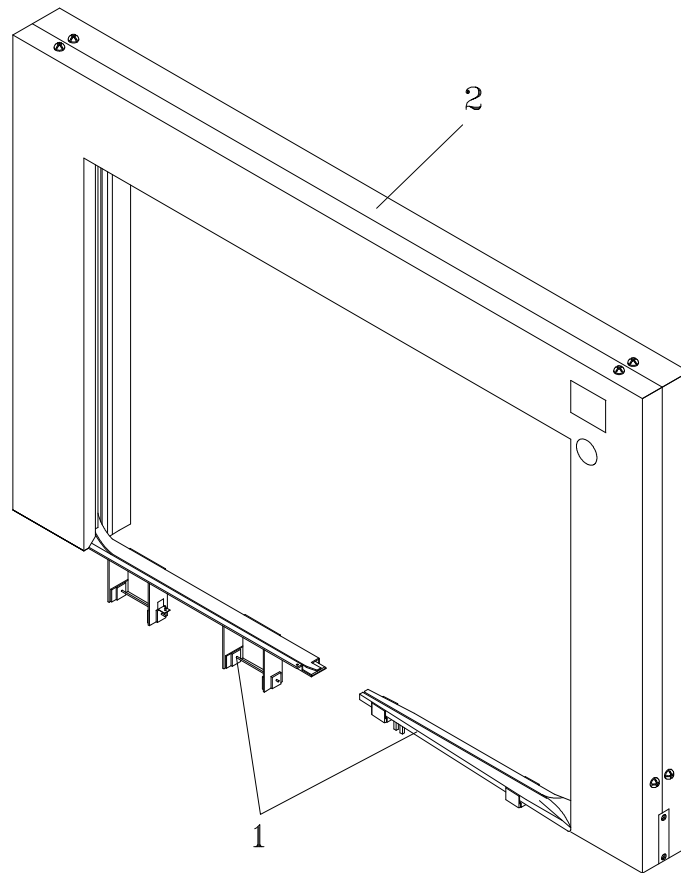

REF. NO.	PART NO.	DESCRIPTION	Q'TY	REMARKS
	T6-2-90000	Bandway Unit (For 12mm)	1	
	T6-2-90000S	Bandway Unit (For 12mm) (Stainless Steel Model)	1	
	T6-2-90007	Bandway Unit (For 9mm)	1	
	T6-2-90007S	Bandway Unit (For 9mm) (Stainless Steel Model)	1	
	T6-2-90018	Bandway Unit (For 15.5mm)	1	
	T6-2-90018S	Bandway Unit (For 15.5mm) (Stainless Steel Model)	1	
1	T6-2-10110	Bandway Group (For 850W, 12mm)	1	SEE PAGE 35
	T6-2-10111	Bandway Group (For 850W, 9mm)	1	SEE PAGE 35
	T6-2-10112	Bandway Group (For 850W, 15.5mm)	1	SEE PAGE 35
	T6-2-10120	Bandway Group (For 650W, 12mm)	1	SEE PAGE 35
	T6-2-10121	Bandway Group (For 650W, 9mm)	1	SEE PAGE 35
	T6-2-10122	Bandway Group (For 650W, 15.5mm)	1	SEE PAGE 35

2-1

BANDWAY GROUP

T6-2-90000

T6-2-90007

REF. NO.	PART NO.	DESCRIPTION	Q'TY	REMARKS
2	T6-2-10140	Bandway Group (For 1050W, 12mm)	1	
	T6-2-10141	Bandway Group (For 1050W, 9mm)	1	
	T6-2-10142	Bandway Group (For 1050W, 15.5mm)	1	
	T6-2-10150	Bandway Group (For 1250W, 12mm)	1	
	T6-2-10151	Bandway Group (For 1250W, 9mm)	1	
	T6-2-10152	Bandway Group (For 1250W, 15.5mm)	1	
	T6-2-10160	Bandway Group (For 1450W, 12mm)	1	
	T6-2-10161	Bandway Group (For 1450W, 9mm)	1	
	T6-2-10162	Bandway Group (For 1450W, 15.5mm)	1	
	T6-2-10170	Bandway Group (For 1650W, 12mm)	1	
	T6-2-10171	Bandway Group (For 1650W, 9mm)	1	
	T6-2-10172	Bandway Group (For 1650W, 15.5mm)	1	
	T6-2-10180	Bandway Group (For 1850W, 12mm)	1	
	T6-2-10181	Bandway Group (For 1850W, 9mm)	1	
	T6-2-10182	Bandway Group (For 1850W, 15.5mm)	1	
	T6-2-20003	Chute Arch Group	1	SEE PAGE 42
	T6-2-20003S	Chute Arch Group (Stainless Steel Model)	1	SEE PAGE 42

2-1

BANDWAY GROUP

T6-2-10110

T6-2-10111

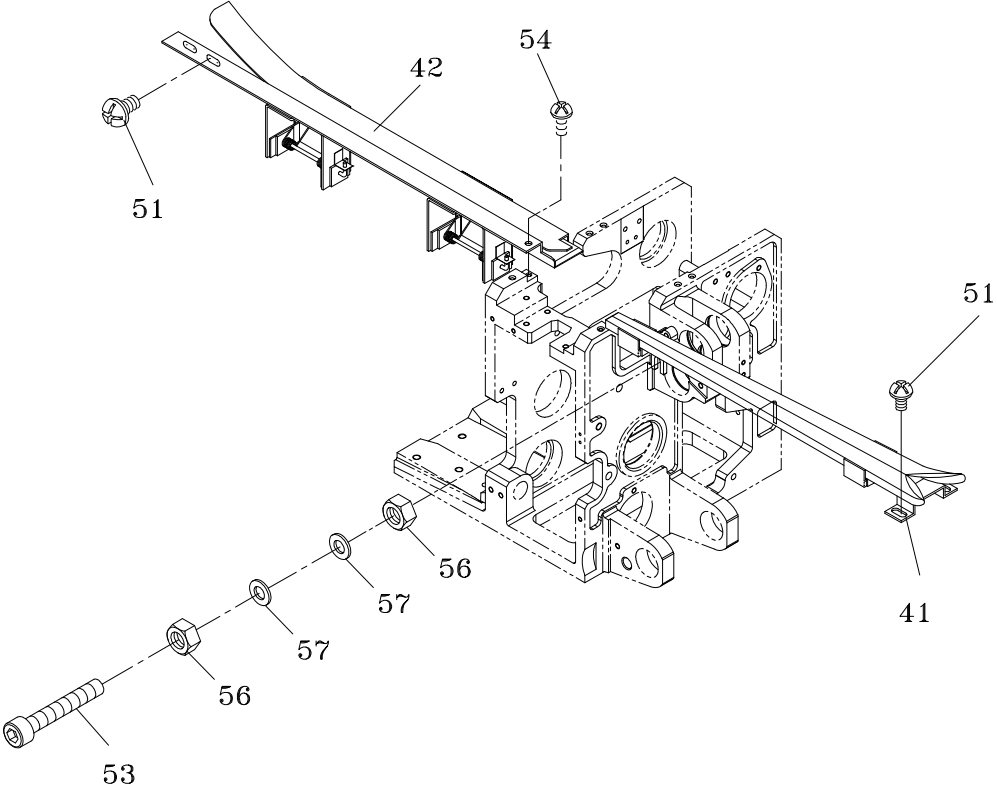

41 (Only 650W)

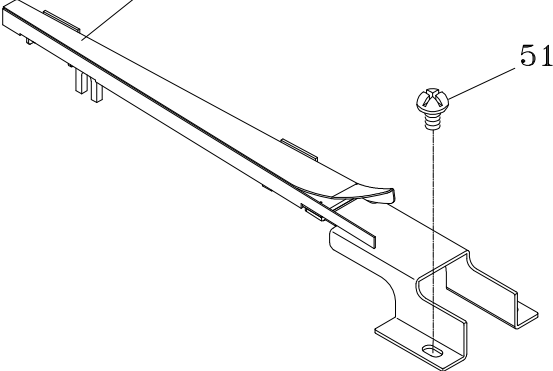

REF. NO.	PART NO.	DESCRIPTION	Q'TY	REMARKS
	T6-2-10110	Bandway Group (For 850W, 12mm)	1	
	T6-2-10111	Bandway Group (For 850W, 9mm)	1	
	T6-2-10112	Bandway Group (For 850W, 15.5mm)	1	
	T6-2-10120	Bandway Group (For 650W, 12mm)	1	
	T6-2-10121	Bandway Group (For 650W, 9mm)	1	
	T6-2-10122	Bandway Group (For 650W, 15.5mm)	1	
	T6-2-10140	Bandway Group (For 1050W, 12mm)	1	
	T6-2-10141	Bandway Group (For 1050W, 9mm)	1	
	T6-2-10142	Bandway Group (For 1050W, 15.5mm)	1	
	T6-2-10150	Bandway Group (For 1250W, 12mm)	1	
	T6-2-10151	Bandway Group (For 1250W, 9mm)	1	
	T6-2-10152	Bandway Group (For 1250W, 15.5mm)	1	
	T6-2-10160	Bandway Group (For 1450W, 12mm)	1	
	T6-2-10161	Bandway Group (For 1450W, 9mm)	1	
	T6-2-10162	Bandway Group (For 1450W, 15.5mm)	1	
	T6-2-10170	Bandway Group (For 1650W, 12mm)	1	
	T6-2-10171	Bandway Group (For 1650W, 9mm)	1	
	T6-2-10172	Bandway Group (For 1650W, 15.5mm)	1	
	T6-2-10180	Bandway Group (For 1850W, 12mm)	1	
	T6-2-10181	Bandway Group (For 1850W, 9mm)	1	
	T6-2-10182	Bandway Group (For 1850W, 15.5mm)	1	
41	T6-2-11000	RH Bandway Ass'y (For 12mm)	1	SEE PAGE 38
	T6-2-11001	RH Bandway Ass'y (For 9mm)	1	SEE PAGE 38
	T6-2-11002	RH Bandway Ass'y (For 15.5mm)	1	SEE PAGE 38
	T6-2-11010	RH Bandway Ass'y (Only 650W, 12mm)	1	SEE PAGE 38
	T6-2-11011	RH Bandway Ass'y (Only 650W, 9mm)	1	SEE PAGE 38
	T6-2-11012	RH Bandway Ass'y (Only 650W, 15.5mm)	1	SEE PAGE 38
42	T6-2-12000	LH Bandway Ass'y (For 850W, 12mm /15.5mm)	1	SEE PAGE 39
	T6-2-12001	LH Bandway Ass'y (For 850W, 9mm)	1	SEE PAGE 39
	T6-2-12010	LH Bandway Ass'y (For 650W, 12mm /15.5mm)	1	SEE PAGE 39
	T6-2-12011	LH Bandway Ass'y (For 650W, 9mm)	1	SEE PAGE 39

REF. NO.	PART NO.	DESCRIPTION	Q'TY	REMARKS
	T6-2-12020	LH Bandway Ass'y (For 1050W, 12mm /15.5mm)	1	SEE PAGE 39
	T6-2-12021	LH Bandway Ass'y (For 1050W, 9mm)	1	SEE PAGE 39
	T6-2-12030	LH Bandway Ass'y (For 1250W, 12mm /15.5mm)	1	SEE PAGE 39
	T6-2-12031	LH Bandway Ass'y (For 1250W, 9mm)	1	SEE PAGE 39
	T6-2-12040	LH Bandway Ass'y (For 1450W, 12mm /15.5mm)	1	SEE PAGE 39
	T6-2-12041	LH Bandway Ass'y (For 1450W, 9mm)	1	SEE PAGE 39
	T6-2-12050	LH Bandway Ass'y (For 1650W, 12mm /15.5mm)	1	SEE PAGE 39
	T6-2-12051	LH Bandway Ass'y (For 1650W, 9mm)	1	SEE PAGE 39
	T6-2-12060	LH Bandway Ass'y (For 1850W, 12mm /15.5mm)	1	SEE PAGE 39
	T6-2-12061	LH Bandway Ass'y (For 1850W, 9mm)	1	SEE PAGE 39
51	TMS0608	TMS, M6x8	4	
53	HBS0650	HBS, M6x50	1	
54	TMS0508	TMS, M5x8	1	
56	HN06	HN, M6	2	
57	PW06A	PW, M6 (A)	2	

2-1-1

RH RANDWAY ASS'Y

T6-2-11000
T6-2-11001

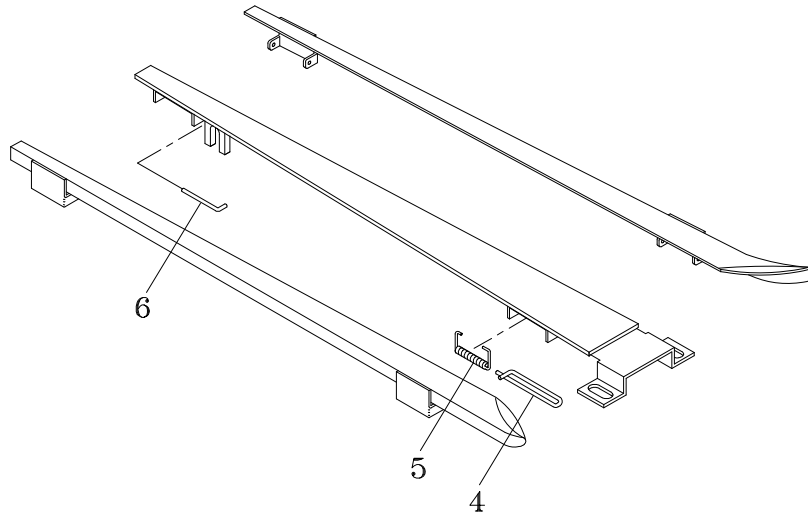

REF. NO.	PART NO.	DESCRIPTION	Q'TY	REMARKS
	T6-2-11000	RH Bandway Ass'y (For 12mm)	1	
	T6-2-11001	RH Bandway Ass'y (For 9mm)	1	
	T6-2-11002	RH Bandway Ass'y (For 15.5mm)	1	
	T6-2-11010	RH Bandway Ass'y (Only 650W, 12mm)	1	
	T6-2-11011	RH Bandway Ass'y (Only 650W, 9mm)	1	
	T6-2-11012	RH Bandway Ass'y (Only 650W, 15.5mm)	1	
4	T6-2-11140	RH Bandway Flap Pin (Rear) RH Bandway Flap Pin (Rear) (Only 650W, 9mm)	2 1	
5	T6-2-11150	RH Bandway Flap Spring RH Bandway Flap Spring (Only 650W, 9mm)	2 1	
6	T6-2-11160	RH Bandway Flap Pin (Front) RH Bandway Flap Pin (Front) (Only 650W, 9mm)	2 1	

2-1-2

LH BANDWAY ASS'Y

T6-2-12000

T6-2-12001

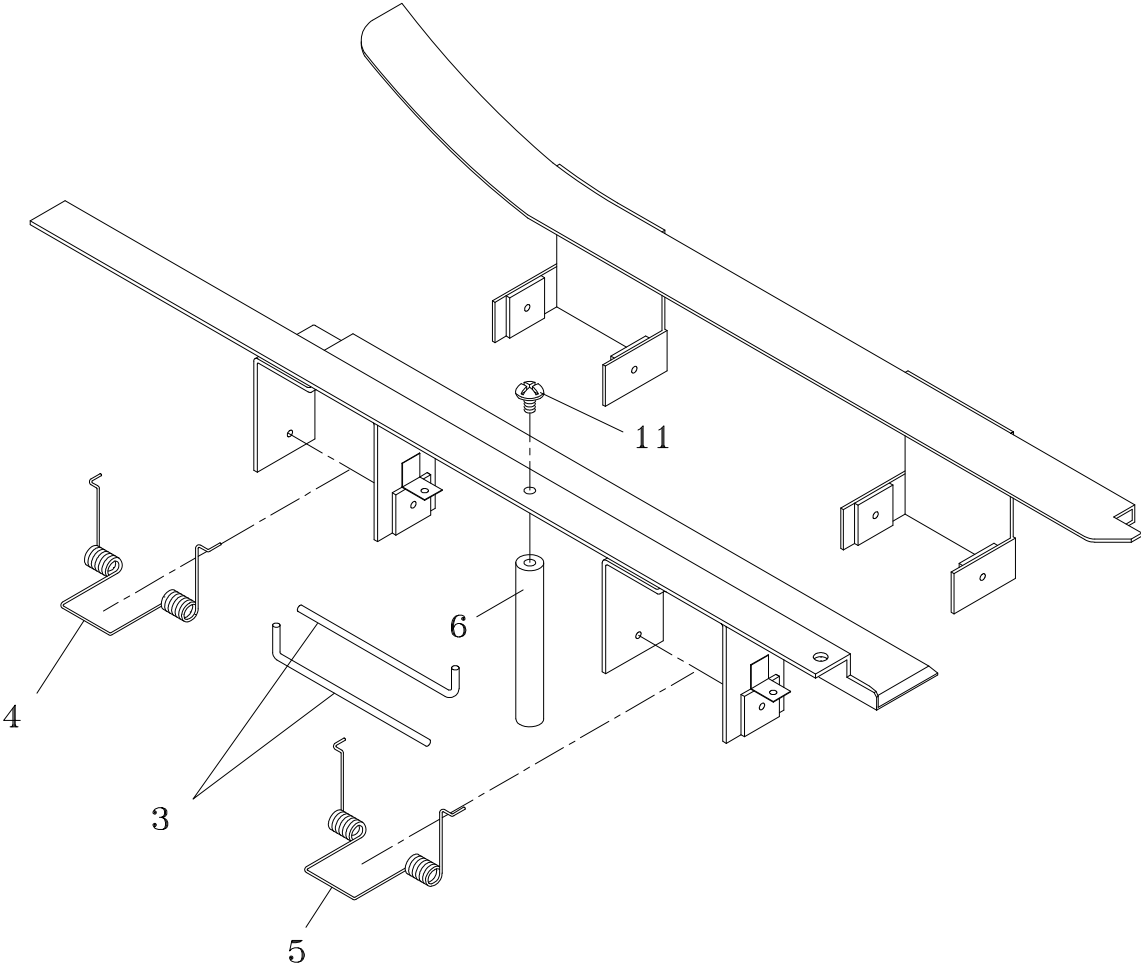

2-1-2

LH BANDWAY ASS'Y

T6-2-12000

T6-2-12001

REF. NO.	PART NO.	DESCRIPTION	Q'TY	REMARKS
	T6-2-12000	LH Bandway Ass'y (For 850W, 12mm/15.5mm)	1	
	T6-2-12001	LH Bandway Ass'y (For 850W, 9mm)	1	
	T6-2-12010	LH Bandway Ass'y (For 650W, 12mm/15.5mm)	1	
	T6-2-12011	LH Bandway Ass'y (For 650W, 9mm)	1	
	T6-2-12020	LH Bandway Ass'y (For 1050W, 12mm/15.5mm)	1	
	T6-2-12021	LH Bandway Ass'y (For 1050W, 9mm)	1	
	T6-2-12030	LH Bandway Ass'y (For 1250W, 12mm/15.5mm)	1	
	T6-2-12031	LH Bandway Ass'y (For 1250W, 9mm)	1	
	T6-2-12040	LH Bandway Ass'y (For 1450W, 12mm/15.5mm)	1	
	T6-2-12041	LH Bandway Ass'y (For 1450W, 9mm)	1	
	T6-2-12050	LH Bandway Ass'y (For 1650W, 12mm/15.5mm)	1	
	T6-2-12051	LH Bandway Ass'y (For 1650W, 9mm)	1	
	T6-2-12060	LH Bandway Ass'y (For 1850W, 12mm/15.5mm)	1	
	T6-2-12061	LH Bandway Ass'y (For 1850W, 9mm)	1	
3	T6-2-12130	LH Bandway Flap Pin (For 650W~1050W)	2	
		LH Bandway Flap Pin (For 1250W~1450W)	3	
		LH Bandway Flap Pin (For 1650W~1850W)	4	
4	T6-2-12140	LH Bandway Flap Spring (For 650~1050W)	1	
		LH Bandway Flap Spring (For 1250~1450W)	2	
		LH Bandway Flap Spring (For 1650~1850W)	3	
5	T6-2-12150	LH Bandway Flap Spring	1	
6	T6-2-12180	Pillar (For 1450W~1850W)	1	
11	TMS0508	TMS, M5x8 (For 1450W~1850W)	1	



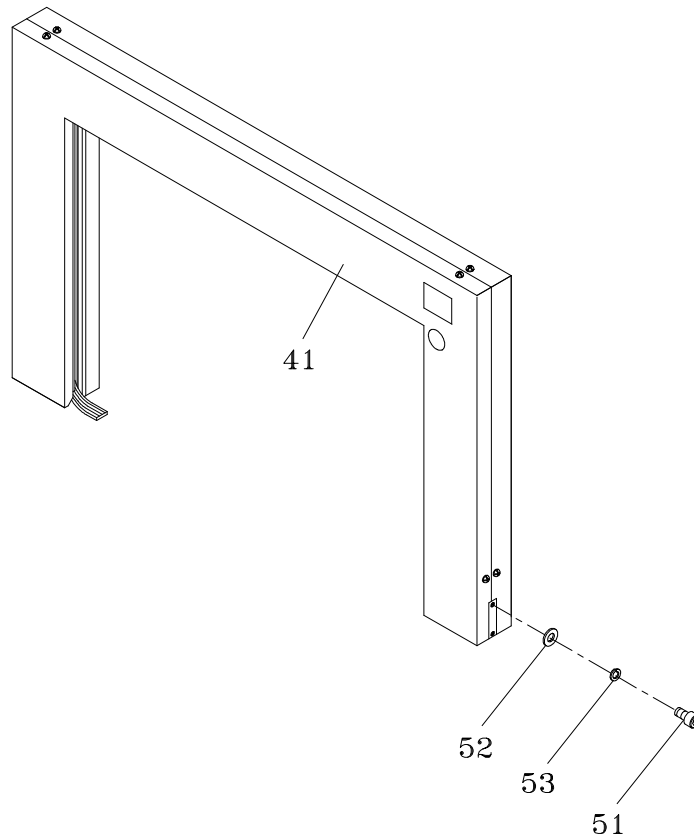

REF. NO.	PART NO.	DESCRIPTION	Q'TY	REMARKS
	T6-2-20003	Chute Arch Group	1	
	T6-2-20003S	Chute Arch Group (Stainless Steel Model)	1	
41	T6-2-21003	Arch Ass'y	1	SEE PAGE 43
	T6-2-21003S	Arch Ass'y (Stainless Steel Model)	1	SEE PAGE 43
51	HBS0816	HBS, M8 x16	4	
	HBS0816S	HBS, M8 x16 (Stainless Steel Model)	4	
52	PW08A	PW, M8 (A)	4	
	PW08AS	PW, M8 (A)(Stainless Steel Model)	4	
53	SW08	SW, M8	4	
	SW08S	SW, M8 (Stainless Steel Model)	4	

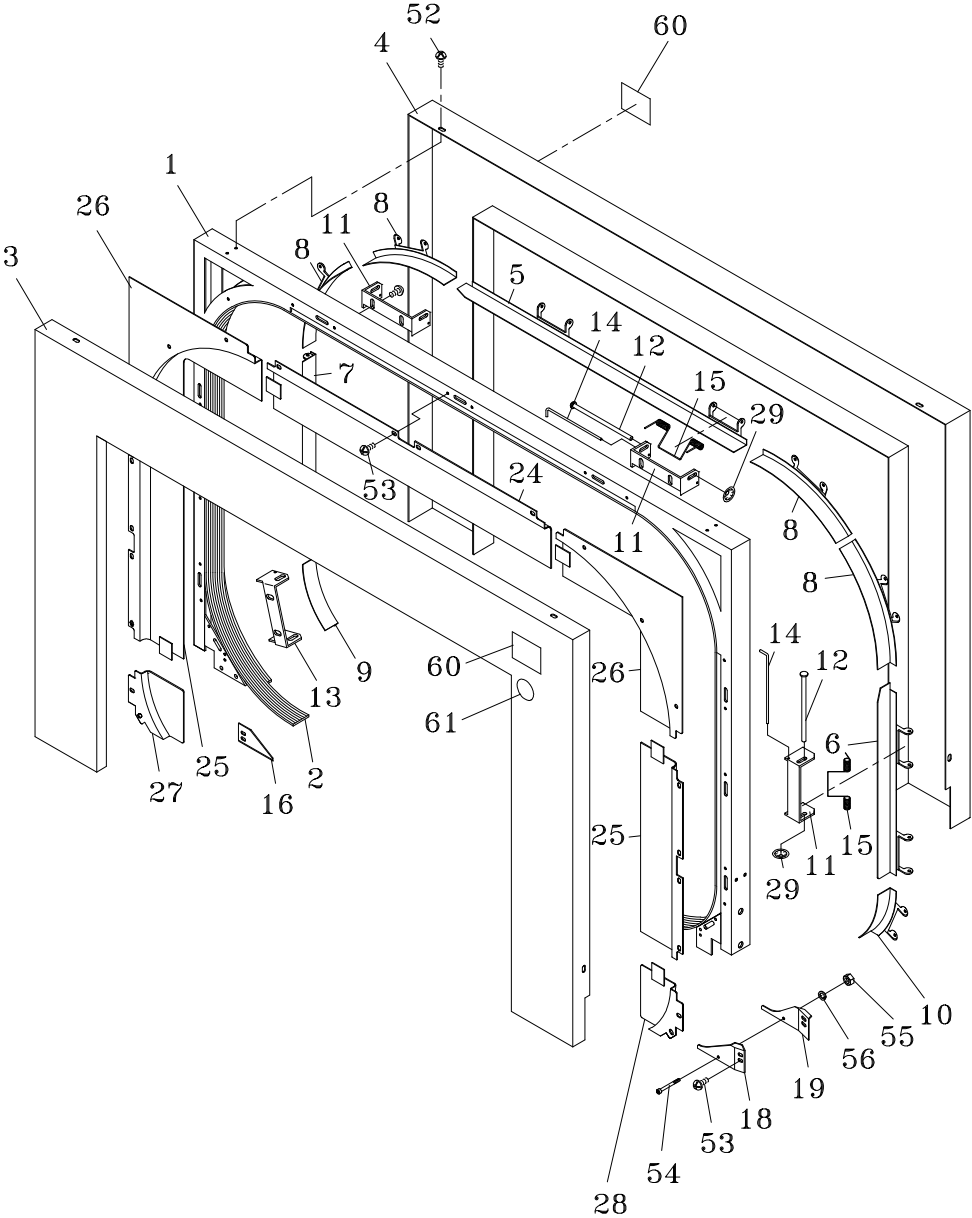

2-2-1**ARCH ASS'Y****T6-2-21003**

REF. NO.	PART NO.	DESCRIPTION	Q'TY	REMARKS
	T6-2-21003	Arch Ass'y	1	
	T6-2-21003S	Arch Ass'y (Stainless Steel Model)	1	
1	T6-2-20110	Arch Frame (For 850Wx600H)	1	
	T6-2-20110S	Arch Frame (For 850Wx600H) (Stainless Steel Model)	1	
2	T6-2-20120	Arch Bandway (For 850Wx600H)	1	
3	T6-2-20146	Arch Cover, Front (For 850Wx600H)	1	
	T6-2-20146S	Arch Cover, Front (For 850Wx600H) (Stainless Steel Model)	1	
4	T6-2-20147	Arch Cover, Rear (For 850Wx600H)	1	
	T6-2-20147S	Arch Cover, Rear (For 850Wx600H) (Stainless Steel Model)	1	
5	T6-2-20150	Upper Guide Rail (For 850W)	1	
	T6-2-20150S	Upper Guide Rail (For 850W) (Stainless Steel Model)	1	
	T6-2-20151	Upper Guide Rail (For 1050W)	1	
	T6-2-20151S	Upper Guide Rail (For 1050W) (Stainless Steel Model)	1	
	T6-2-20152	Upper Guide Rail (For 1250W)	1	
	T6-2-20152S	Upper Guide Rail (For 1250W) (Stainless Steel Model)	1	
	T6-2-20153	Upper Guide Rail (For 1450W)	1	
	T6-2-20153S	Upper Guide Rail (For 1450W) (Stainless Steel Model)	1	
	T6-2-20154	Upper Guide Rail (For 1650W)	1	
	T6-2-20154S	Upper Guide Rail (For 1650W) (Stainless Steel Model)	1	
	T6-2-20155	Upper Guide Rail (For 1850W)	1	
	T6-2-20155S	Upper Guide Rail (For 1850W) (Stainless Steel Model)	1	
	T6-2-20159	Upper Guide Rail (For 650W)	1	
	T6-2-20159S	Upper Guide Rail (For 650W) (Stainless Steel Model)	1	
6	T6-2-20160	RH Side Guide Rail (For 600H)	1	
	T6-2-20160S	RH Side Guide Rail (For 600H) (Stainless Steel Model)	1	

2-2-1**ARCH ASS'Y****T6-2-21003**

REF. NO.	PART NO.	DESCRIPTION	Q'TY	REMARKS
	T6-2-20161	RH Side Guide Rail (For 800H)	1	
	T6-2-20161S	RH Side Guide Rail (For 800H) (Stainless Steel Model)	1	
	T6-2-20162	RH Side Guide Rail (For 1000H)	1	
	T6-2-20162S	RH Side Guide Rail (For 1000H) (Stainless Steel Model)	1	
	T6-2-20163	RH Side Guide Rail (For 1200H)	1	
	T6-2-20163S	RH Side Guide Rail (For 1200H) (Stainless Steel Model)	1	
	T6-2-20169	RH Side Guide Rail (For 400H)	1	
	T6-2-20169S	RH Side Guide Rail (For 400H) (Stainless Steel Model)	1	
7	T6-2-20170	LH Side Guide Rail (For 600H)	1	
	T6-2-20170S	LH Side Guide Rail (For 600H) (Stainless Steel Model)	1	
	T6-2-20171	LH Side Guide Rail (For 800H)	1	
	T6-2-20171S	LH Side Guide Rail (For 800H) (Stainless Steel Model)	1	
	T6-2-20172	LH Side Guide Rail (For 1000H)	1	
	T6-2-20172S	LH Side Guide Rail (For 1000H) (Stainless Steel Model)	1	
	T6-2-20173	LH Side Guide Rail (For 1200H)	1	
	T6-2-20173S	LH Side Guide Rail (For 1200H) (Stainless Steel Model)	1	
	T6-2-20179	LH Side Guide Rail (For 400H)	1	
	T6-2-20179S	LH Side Guide Rail (For 400H) (Stainless Steel Model)	1	
8	T6-2-20180	Corner Guide Rail, Upper	4	
	T6-2-20180S	Corner Guide Rail, Upper (Stainless Steel Model)	4	
9	T6-2-20190	Corner Guide Rail, Lower (LH)	1	
	T6-2-20190S	Corner Guide Rail, Lower (LH) (Stainless Steel Model)	1	
10	T6-2-20200	Corner Guide Rail, Lower (RH)	1	
	T6-2-20200S	Corner Guide Rail, Lower (RH) (Stainless Steel Model)	1	

2-2-1**ARCH ASS'Y****T6-2-21003**

REF. NO.	PART NO.	DESCRIPTION	Q'TY	REMARKS
11	T6-2-20210	Guide Rail Hinge (1) (For 850Wx600H)	11	
12	T6-2-20220	K-Type Guide Rail Hinge Shaft (For 850Wx600H)	12	
13	T6-2-20230	Guide Rail Hinge (2)	1	
14	T6-2-20240	Guide Rail Hinge Shaft (For 850Wx600H)	11	
15	T6-2-21250	Arch Guide Rail Spring (For 850Wx600H)	11	
16	T6-2-21260	Guiding Angle, LH Front	1	
	T6-2-21260S	Guiding Angle, LH Front (Stainless Steel Model)	1	
18	T6-2-21280	Guiding Angle, RH Front	1	
	T6-2-21280S	Guiding Angle, RH Front (Stainless Steel Model)	1	
19	T6-2-21290	Guiding Angle, RH Rear	1	
	T6-2-21290S	Guiding Angle, RH Rear (Stainless Steel Model)	1	
24	T6-2-20340	Back Guide Plate, Upper (For 850W)	1	
	T6-2-20340S	Back Guide Plate, Upper (For 850W) (Stainless Steel Model)	1	
	T6-2-20341	Back Guide Plate, Upper (For 1050W)	1	
	T6-2-20341S	Back Guide Plate, Upper (For 1050W) (Stainless Steel Model)	1	
	T6-2-20342	Back Guide Plate, Upper (For 1250W)	1	
	T6-2-20342S	Back Guide Plate, Upper (For 1250W) (Stainless Steel Model)	1	
	T6-2-20343	Back Guide Plate, Upper (For 1450W)	1	
	T6-2-20343S	Back Guide Plate, Upper (For 1450W) (Stainless Steel Model)	1	
	T6-2-20344	Back Guide Plate, Upper (For 1650W)	1	
	T6-2-20344S	Back Guide Plate, Upper (For 1650W) (Stainless Steel Model)	1	

2-2-1**ARCH ASS'Y****T6-2-21003**

REF. NO.	PART NO.	DESCRIPTION	Q'TY	REMARKS
	T6-2-20345	Back Guide Plate, Upper (For 1850W)	1	
	T6-2-20345S	Back Guide Plate, Upper (For 1850W) (Stainless Steel Model)	1	
	T6-2-20349	Back Guide Plate, Upper (For 650W)	1	
	T6-2-20349S	Back Guide Plate, Upper (For 650W) (Stainless Steel Model)	1	
25	T6-2-21350	Back Guide Plate, Side (For 600H)	2	
	T6-2-21350S	Back Guide Plate, Side (For 600H) (Stainless Steel Model)	2	
	T6-2-21351	Back Guide Plate, Side (For 800H)	2	
	T6-2-21351S	Back Guide Plate, Side (For 800H) (Stainless Steel Model)	2	
	T6-2-21352	Back Guide Plate, Side (For 1000H)	2	
	T6-2-21352S	Back Guide Plate, Side (For 1000H) (Stainless Steel Model)	2	
	T6-2-21353	Back Guide Plate, Side (For 1200H)	2	
	T6-2-21353S	Back Guide Plate, Side (For 1200H) (Stainless Steel Model)	2	
	T6-2-21359	Back Guide Plate, Side (For 400H)	2	
	T6-2-21359S	Back Guide Plate, Side (For 400H) (Stainless Steel Model)	2	
26	T6-2-21360	Back Guide Plate, Corner Upper	2	
	T6-2-21360S	Back Guide Plate, Corner Upper (Stainless Steel Model)	2	
27	T6-2-21370	Back Guide Plate, LH Lower	1	
	T6-2-21370S	Back Guide Plate, LH Lower (Stainless Steel Model)	1	
28	T6-2-21380	Back Guide Plate, RH Lower	1	
	T6-2-21380S	Back Guide Plate, RH Lower (Stainless Steel Model)	1	
29	PN04	PN, ϕ 4 (For 850Wx600H)	12	
	PN04S	PN, ϕ 4 (For 850Wx600H) (Stainless Steel Model)	12	
		PN, ϕ 4 (For 850Wx600H) (SUS)(Option)	12	

2-2-1**ARCH ASS'Y****T6-2-21003**

REF. NO.	PART NO.	DESCRIPTION	Q'TY	REMARKS
52	TMS0508S	TMS, M5x8 (SUS)	8	
53	TMS0408	TMS, M4x8 (For 850Wx600H)	72	
	TMS0408S	TMS, M4x8 (For 850Wx600H) (Stainless Steel Model)	72	
54	HBS0440H	HBS, M4x40 (H)	1	
	HBS0440HS	HBS, M4x40 (H)(Stainless Steel Model)	1	
55	HN04	HN, M4	1	
	HN04S	HN, M4 (Stainless Steel Model)	1	
56	SW04	SW, M4	1	
	SW04S	SW, M4 (Stainless Steel Model)	1	
60	LA-40005	Label	2	
61	LA-40170	Label	1	

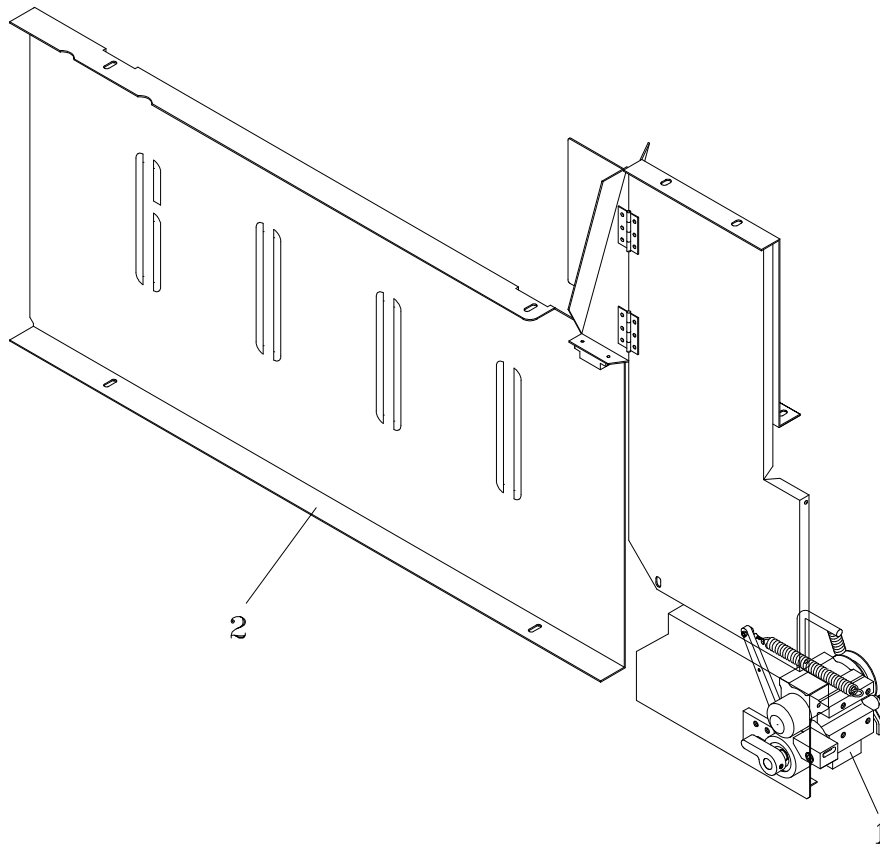

REF. NO.	PART NO.	DESCRIPTION	Q'TY	REMARKS
1	T6-3-90004	Accumulator Unit (For 12mm)	1	
	T6-3-90004S	Accumulator Unit (For 12mm) (Stainless Steel Model)	1	
	T6-3-90005	Accumulator Unit (For 15.5mm)	1	
	T6-3-90005S	Accumulator Unit (For 15.5mm) (Stainless Steel Model)	1	
	T6-3-90008	Accumulator Unit (For 9mm)	1	
	T6-3-90008S	Accumulator Unit (For 9mm) (Stainless Steel Model)	1	
	T6-3-10000	Accumulator Group (For 12mm)	1	SEE PAGE 51
	T6-3-10000S	Accumulator Group (For 12mm) (Stainless Steel Model)	1	SEE PAGE 51
	T6-3-10003	Accumulator Group (For 9mm)	1	SEE PAGE 51
	T6-3-10003S	Accumulator Group (For 9mm) (Stainless Steel Model)	1	SEE PAGE 51
	T6-3-10004	Accumulator Group (For 15.5mm)	1	SEE PAGE 51
	T6-3-10004S	Accumulator Group (For 15.5mm) (Stainless Steel Model)	1	SEE PAGE 51

REF. NO.	PART NO.	DESCRIPTION	Q'TY	REMARKS
2	T6-3-20000	Accumulator Box Group (For 12mm)	1	SEE PAGE 56
	T6-3-20000S	Accumulator Box Group (For 12mm) (Stainless Steel Model)	1	SEE PAGE 56
	T6-3-20003	Accumulator Box Group (For 9mm)	1	SEE PAGE 56
	T6-3-20003S	Accumulator Box Group (For 9mm) (Stainless Steel Model)	1	SEE PAGE 56
	T6-3-20004	Accumulator Box Group (For 15.5mm)	1	SEE PAGE 56
	T6-3-20004S	Accumulator Box Group (For 15.5mm) (Stainless Steel Model)	1	SEE PAGE 56

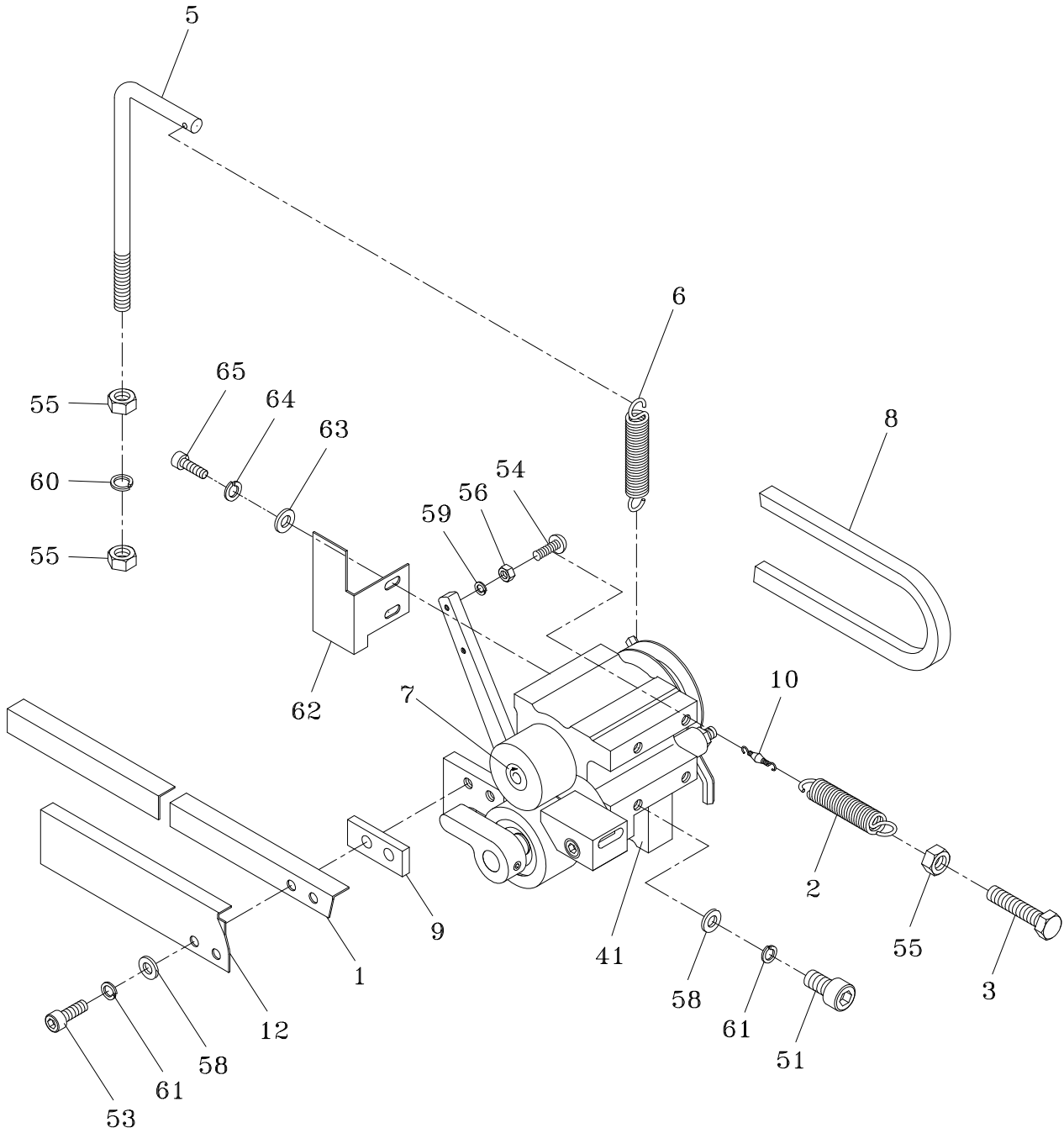

3-1**ACCUMULATOR GROUP****T6-3-10000****T6-3-10003**

REF. NO.	PART NO.	DESCRIPTION	Q'TY	REMARKS
	T6-3-10000	Accumulator Group (For 12mm)	1	
	T6-3-10000S	Accumulator Group (For 12mm) (Stainless Steel Model)	1	
	T6-3-10003	Accumulator Group (For 9mm)	1	
	T6-3-10003S	Accumulator Group (For 9mm) (Stainless Steel Model)	1	
	T6-3-10004	Accumulator Group (For 15.5mm)	1	
	T6-3-10004S	Accumulator Group (For 15.5mm) (Stainless Steel Model)	1	
1	T6-3-10110	Balance Bar (For 12mm)	1	
	T6-3-10111	Balance Bar (For 9mm)	1	
	T6-3-10112	Balance Bar (For 15.5mm)	1	
2	T6-3-10120	Accumulator Balance Spring	1	
3	T6-3-10130	Accumulator Adjusting Bolt	1	
	T6-3-10130S	Accumulator Adjusting Bolt (Stainless Steel Model)	1	
5	T6-3-10150	Accumulator Spring Adjusting	1	
6	T6-1-72140	Spring	1	
7	LA-50200	Label (Direction)	1	
8	T6-3-10181	V-Belt, M-27	1	
9	T6-3-10190	Balance Bar Spacer (For 12mm/ 15.5mm)	1	
10	T6-3-10200	Twist Stopper	1	
12	T6-3-10220	Guide Cover (For 12mm)	1	
	T6-3-10221	Guide Cover (For 9mm)	1	
	T6-3-10222	Guide Cover (For 15.5mm)	1	
41	T6-3-11000	Accumulator Ass'y (For 12mm)	1	SEE PAGE 54
	T6-3-11001	Accumulator Ass'y (For 9mm)	1	SEE PAGE 54
	T6-3-11002	Accumulator Ass'y (For 15.5mm)	1	SEE PAGE 54

REF. NO.	PART NO.	DESCRIPTION	Q'TY	REMARKS
51	HBS0620	HBS, M6x20	4	
	HBS0620S	HBS, M6x20 (Stainless Steel Model)	4	
53	HBS0616	HBS, M6x16 (For 9mm/12mm)	2	
	HBS0620	HBS, M6x20 (For 15.5mm)	2	
54	PMS0315	PMS, M3x15	1	
55	HN08	HN, M8	3	
	HN08S	HN, M8 (Stainless Steel Model)	3	
56	HN03	HN, M3	1	
58	PW06A	PW, M6 (A)	4	
	PW06AS	PW, M6 (A)(Stainless Steel Model)	4	
59	SW03	SW, M3	1	
60	SW08	SW, M8	1	
61	SW06	SW, M6	4	
	SW06S	SW, M6 (Stainless Steel Model)	4	
62	T6-3-10321	Cover	1	
63	PW05	PW, M5	2	
64	SW05	SW, M5	2	
65	HBS0510	HBS, M5x10	2	

3-1-1

ACCUMULATOR ASS'Y

T6-3-11000
T6-3-11001

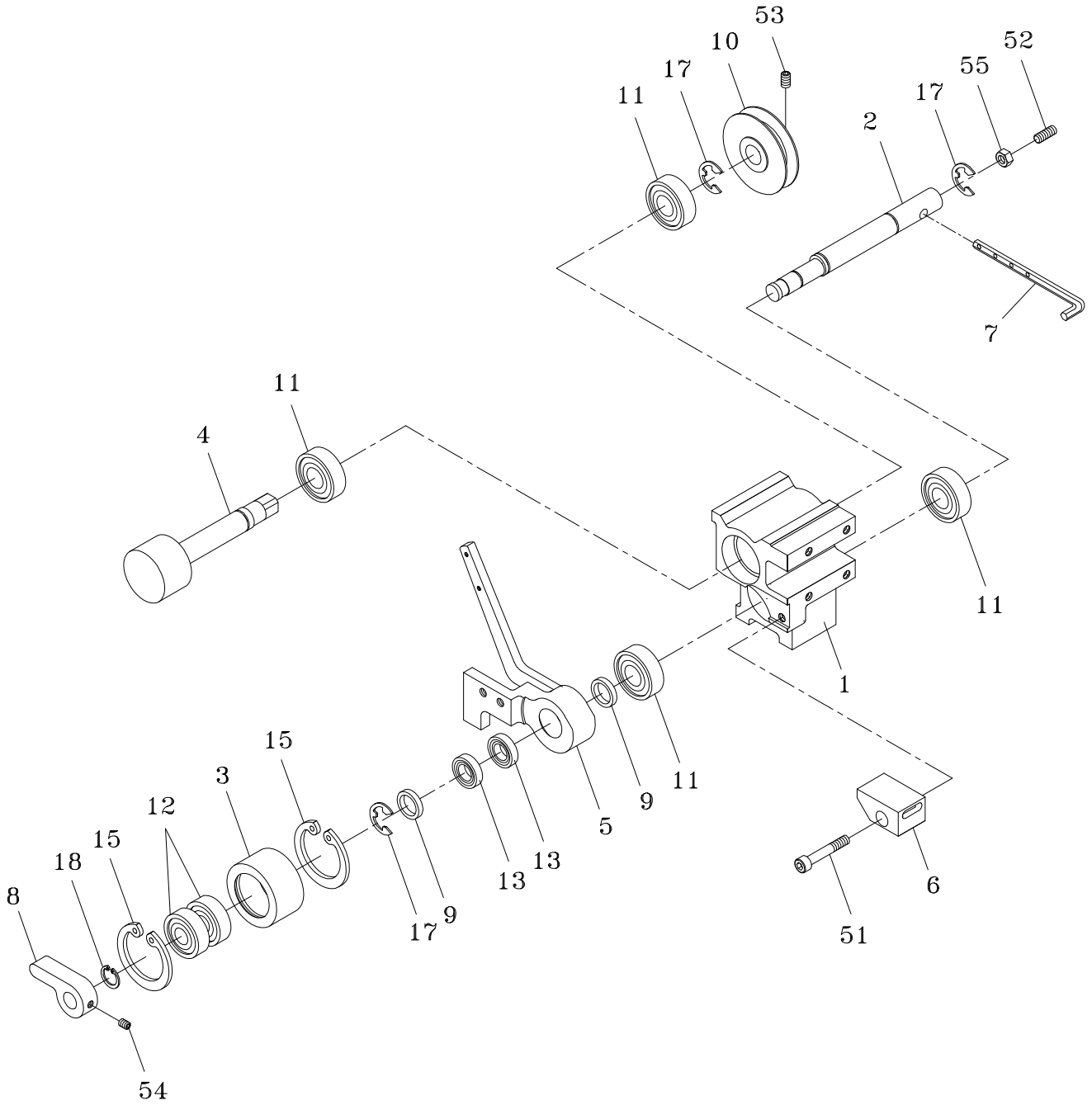

3-1-1**ACCUMULATOR ASS'Y****T6-3-11000****T6-3-11001**

REF. NO.	PART NO.	DESCRIPTION	Q'TY	REMARKS
	T6-3-11000	Accumulator Ass'y (For 12mm)	1	
	T6-3-11001	Accumulator Ass'y (For 9mm)	1	
	T6-3-11002	Accumulator Ass'y (For 15.5mm)	1	
1	T6-3-11110	Accumulator Bearing Case	1	
2	T6-3-11120	Accumulator Lower Shaft	1	
3	T6-3-11130	Accumulator Lower Roller	1	
4	T6-3-11140	Accumulator Main Roller & Shaft	1	
5	T6-3-11150	Accumulator Balance Bar Holder	1	
6	T6-3-11160	Accumulator Feed Shooter (For 12mm)	1	
	T6-3-11161	Accumulator Feed Shooter (For 9mm)	1	
	T6-3-11162	Accumulator Feed Shooter (For 15.5mm)	1	
7	T6-3-11170	Accumulator Lower Shaft Spring Hook	1	
8	T6-3-11180	Knob	1	
9	T6-3-11190	Bearing Collar	2	
10	T6-1-71160	Feed Roller Pulley	1	
11	BR6202ZZ	Bearing, 6202ZZ	4	
12	BR6201ZZ	Bearing, 6201ZZ	2	
13	BR6902ZZ	Bearing, 6902ZZ	2	
15	RR32	Snap Ring, H-32	2	
17	ER12	Snap Ring, E-12	3	
18	SR12	Stop Ring, S-12	1	
51	HBS0635H	HBS, M6x35 (H)	1	
52	HSS0615G	HSS, M6x15 (G)	1	
53	HSS0610G	HSS, M6x10 (G)	2	
54	HSS0506G	HSS, M5x6 (G)	1	
55	HN06	HN, M6	1	

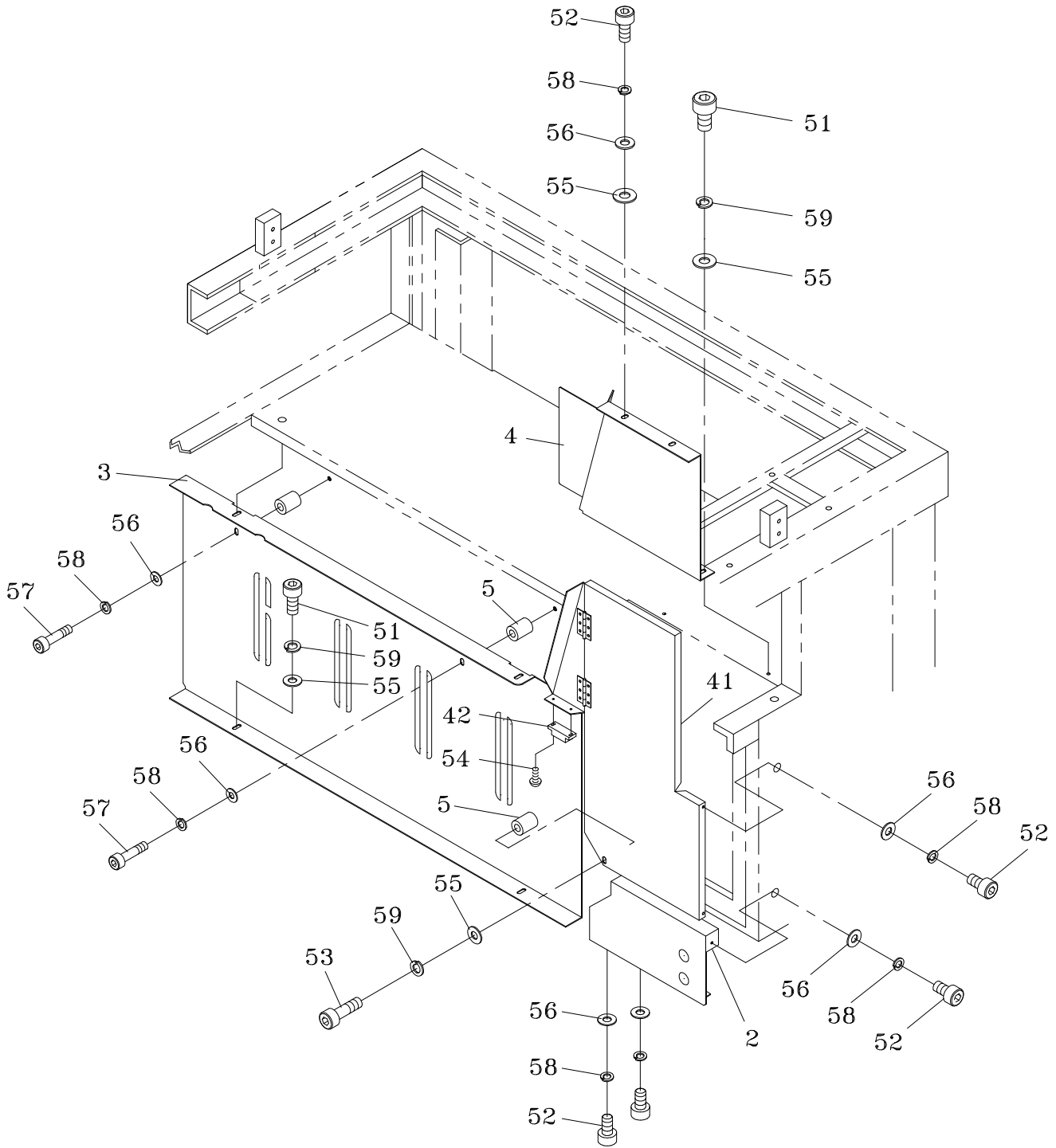

3-2

ACCUMULATOR BOX GROUP

T6-3-20000

T6-3-20003

REF. NO.	PART NO.	DESCRIPTION	Q'TY	REMARKS
	T6-3-20000	Accumulator Box Group (For 12mm)	1	
	T6-3-20000S	Accumulator Box Group (For 12mm) (Stainless Steel Model)	1	
	T6-3-20003	Accumulator Box Group (For 9mm)	1	
	T6-3-20003S	Accumulator Box Group (For 9mm) (Stainless Steel Model)	1	
	T6-3-20004	Accumulator Box Group (For 15.5mm)	1	
	T6-3-20004S	Accumulator Box Group (For 15.5mm) (Stainless Steel Model)	1	
2	T6-3-20120	Accumulator Box Front, RH	1	
	T6-3-20120S	Accumulator Box Front, RH (Stainless Steel Model)	1	
3	T6-3-20130	Accumulator Box Front, LH	1	
	T6-3-20130S	Accumulator Box Front, LH (Stainless Steel Model)	1	
4	T6-3-20140	Accumulator Box Rear	1	
	T6-3-20140S	Accumulator Box Rear (Stainless Steel Model)	1	
5	T6-3-20150	Spacer (For 9 mm)	3	
	T6-3-20160	Spacer (For 12 mm)	3	
	T6-3-20170	Spacer (For 15.5 mm)	3	
41	T6-3-20510	Accumulator Box Front, RH Upper (With Door)	1	
	T6-3-20510S	Accumulator Box Front, RH Upper (With Door)(Stainless Steel Model)	1	
42	T6-3-20520	Magnet Catch	1	
51	HBS0510	HBS, M5x10	4	
	HBS0510S	HBS, M5x10 (Stainless Steel Model)	4	
52	HBS0408	HBS, M4x8	7	
	HBS0408S	HBS, M4x8 (Stainless Steel Model)	7	
53	HBS0525H	HBS, M5x25 (H)(For 9mm/12mm)	1	
	HBS0525HS	HBS, M5x25 (H)(For 9mm/12mm) (Stainless Steel Model)	1	
	HBS0530H	HBS, M5x30 (H)(For 15.5mm)	1	
	HBS0530HS	HBS, M5x30 (H)(For 15.5mm) (Stainless Steel Model)	1	

REF. NO.	PART NO.	DESCRIPTION	Q'TY	REMARKS
54	TMS0308	TMS, M3x8	2	
55	PW05	PW, M5	7	
	PW05S	PW, M5 (Stainless Steel Model)	7	
56	PW04	PW, M4	9	
	PW04S	PW, M4 (Stainless Steel Model)	9	
57	HBS0430H	HBS, M4x30 (H)	2	
	HBS0430HS	HBS, M4x30 (H)(Stainless Steel Model)	2	
58	SW04	SW, M4	7	
	SW04S	SW, M4 (Stainless Steel Model)	7	
59	SW05	SW, M5	4	
	SW05S	SW, M5 (Stainless Steel Model)	4	

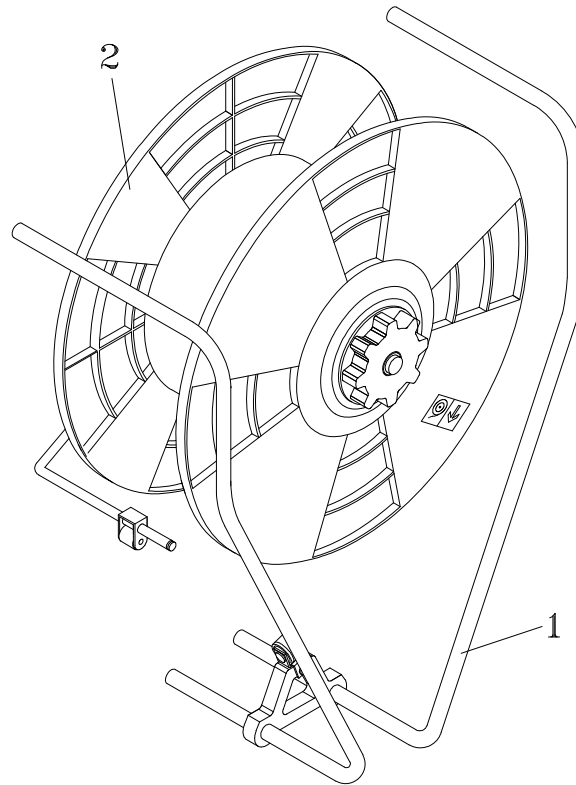

REF. NO.	PART NO.	DESCRIPTION	Q'TY	REMARKS
1	T6-4-90000	Reel Unit	1	
	T6-4-90000S	Reel Unit (Stainless Steel Model)	1	
	T6-4-10000	Reel Guard Group	1	SEE PAGE 60
	T6-4-10000S	Reel Guard Group (Stainless Steel Model)	1	SEE PAGE 60
2	T6-4-20000	Reel Control Group (For 200mm)	1	SEE PAGE 62
	T6-4-20000S	Reel Control Group (For 200mm) (Stainless Steel Model)	1	SEE PAGE 62
	T6-4-20007	Reel Control Group (For 280mm) (Option)	1	SEE PAGE 62
	T6-4-20007S	Reel Control Group (For 280mm) (Stainless Steel Model)(Option)	1	SEE PAGE 62

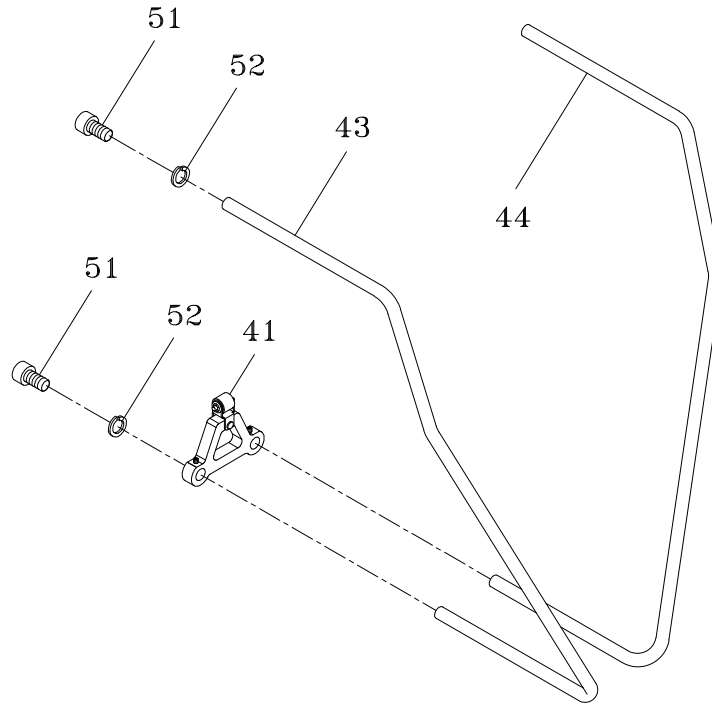

REF. NO.	PART NO.	DESCRIPTION	Q'TY	REMARKS
	T6-4-10000	Reel Guard Group	1	
	T6-4-10000S	Reel Guard Group (Stainless Steel Model)	1	
41	T6-4-11000	Free Angle Bracket Holder Ass'y	1	SEE PAGE 61
	T6-4-11000S	Free Angle Bracket Holder Ass'y (Stainless Steel Model)	1	SEE PAGE 61
43	T6-4-10530	Reel Guard (Front)	1	
	T6-4-10530S	Reel Guard (Front)(Stainless Steel Model)	1	
44	T6-4-10540	Reel Guard (Rear)	1	
	T6-4-10540S	Reel Guard (Rear)(Stainless Steel Model)	1	
51	HBS1020	HBS, M10x20	4	
	HBS1020S	HBS, M10x20 (Stainless Steel Model)	4	
52	SW10	SW, M10	4	
	SW10S	SW, M10 (Stainless Steel Model)	4	

4-1-1

**FREE ANGLE BRACKET
HOLDER ASS'Y**

T6-4-11000

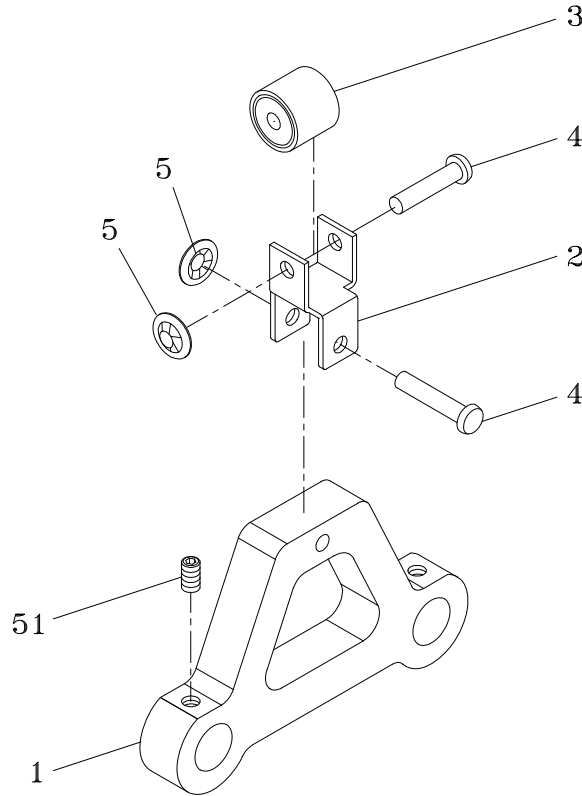

REF. NO.	PART NO.	DESCRIPTION	Q'TY	REMARKS
	T6-4-11000	Free Angle Bracket Holder Ass'y	1	
	T6-4-11000S	Free Angle Bracket Holder Ass'y (Stainless Steel Model)	1	
1	T6-4-11110	Free Angle Bracket Holder	1	
2	T6-4-11120	Free Angle Roller Bracket	1	
3	T6-4-11130	Strap Guide Roller	1	
4	T6-4-11140	Rivet, Ø6x30	2	
	T6-4-11140S	Rivet, Ø6x30 (Stainless Steel Model)	2	
5	PN06	PN, Ø6	2	
	PN06S	PN, Ø6 (Stainless Steel Model)	2	
51	HSS0610G	HSS, M6x10 (G)	2	
	HSS0610S	HSS, M6x10 (Stainless Steel Model)	2	

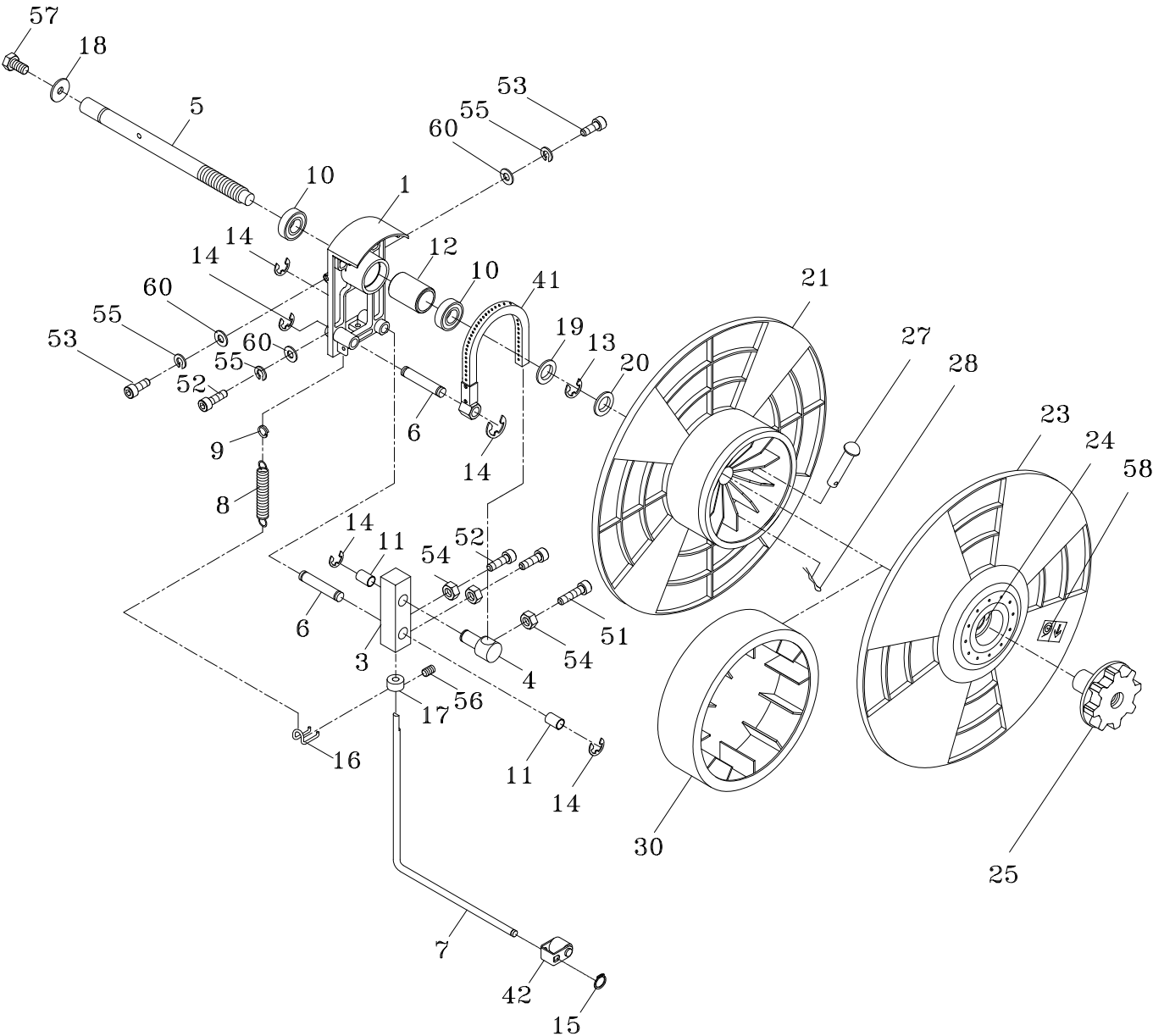

REF. NO.	PART NO.	DESCRIPTION	Q'TY	REMARKS
	T6-4-20000	Reel Control Group (For 200mm)	1	
	T6-4-20000S	Reel Control Group (For 200mm) (Stainless Steel Model)	1	
	T6-4-20007	Reel Control Group (For 280mm) (Option)	1	
	T6-4-20007S	Reel Control Group (For 280mm) (Stainless Steel Model)(Option)	1	
1	T6-4-20110	Reel Unit Base	1	
3	T6-4-20130	Brake Tension Holder	1	
4	T6-4-20140	Brake Belt Tightener	1	
	T6-4-20140S	Brake Belt Tightener (Stainless Steel Model)	1	
5	T6-4-20150	Reel Shaft	1	
	T6-4-20150S	Reel Shaft (Stainless Steel Model)	1	
6	T6-4-20160	Holder Shaft	2	
	T6-4-20160S	Holder Shaft (Stainless Steel Model)	2	
7	T6-4-20170	Reel Brake Arm	1	
	T6-4-20170S	Reel Brake Arm (Stainless Steel Model)	1	
8	T6-4-20180	Brake Tension Arm Spring	1	
	T6-4-20180S	Brake Tension Arm Spring (Stainless Steel Model)	1	
9	T6-4-20190	Brake Tension Spring Ring	1	
10	BR6205ZZ	Bearing, 6205ZZ	2	
11	MB1525	Metal Bushing, 1525	2	
12	T6-4-20310	Collar	1	
13	ER19	Snap Ring, E-19	1	
	ER19S	Snap Ring, E-19 (Stainless Steel Model)	1	
14	ER12	Snap Ring, E-12	5	
	ER12S	Snap Ring, E-12 (Stainless Steel Model)	5	
15	SR08	Stop Ring, S-8	1	
	SR08S	Stop Ring, S-8 (Stainless Steel Model)	1	
16	T6-4-20260	Spring Hook	1	
17	T6-4-20270	Set Block	1	
	T6-4-20270S	Set Block (Stainless Steel Model)	1	

REF. NO.	PART NO.	DESCRIPTION	Q'TY	REMARKS
18	T6-4-20280	Washer	1	
	T6-4-20280S	Washer (Stainless Steel Model)	1	
19	T6-4-20290	Collar	1	
20	T6-4-20300	Collar	1	
21	TC-013	Inner Flange	1	
23	TC-014	Outer Flange	1	
24	TC-015	Protector	1	
25	TC-016	Reel Nut Handle	1	
27	TC-020	Pin	1	
28	TC-021	Split Pin	1	
30	TC-075	Center Drum (For 280mm)(Option)	1	
41	T6-4-21000	Brake Belt Ass'y	1	SEE PAGE 65
	T6-4-21000S	Brake Belt Ass'y (Stainless Steel Model)	1	SEE PAGE 65
42	T6-4-22000	Free Slide Roller Ass'y	1	SEE PAGE 66
	T6-4-22000S	Free Slide Roller Ass'y (Stainless Steel Model)	1	SEE PAGE 66
51	HBS0625	HBS, M6x25	1	
	HBS0625S	HBS, M6x25 (Stainless Steel Model)	1	
52	HBS0620	HBS, M6x20	3	
	HBS0620S	HBS, M6x20 (Stainless Steel Model)	3	
53	HBS0616	HBS, M6x16	2	
	HBS0616S	HBS, M6x16 (Stainless Steel Model)	2	
54	HN06	HN, M6	3	
	HN06S	HN, M6 (Stainless Steel Model)	3	
55	SW06	SW, M6	3	
	SW06S	SW, M6 (Stainless Steel Model)	3	
56	HSS0606G	HSS, M6x6 (G)	1	
	HSS0606S	HSS, M6x6 (Stainless Steel Model)	1	
57	HB0816	HB, M8x16	1	
	HB0816S	HB, M8x16 (Stainless Steel Model)	1	
58	LA-31010	Label	1	
60	PW06A	PW, M6 (A)	3	
	PW06AS	PW, M6 (A)(Stainless Steel Model)	3	

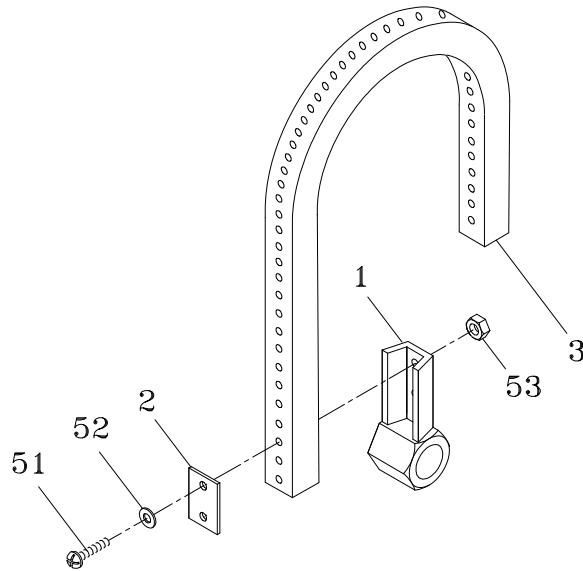

REF. NO.	PART NO.	DESCRIPTION	Q'TY	REMARKS
1	T6-4-21000	Brake Belt Ass'y	1	
	T6-4-21000S	Brake Belt Ass'y (Stainless Steel Model)	1	
	T6-4-21110	Brake Belt Holder	1	
2	T6-4-21110S	Brake Belt Holder (Stainless Steel Model)	1	
	T6-4-21120	Brake Holder Plate	1	
3	T6-4-21120S	Brake Holder Plate (Stainless Steel Model)	1	
	T6-4-21130	Brake V-Belt	1	
51	PMS0420	PMS, M4x20	2	
	PMS0420S	PMS, M4x20 (Stainless Steel Model)	2	
52	PW04	PW, M4	2	
	PW04S	PW, M4 (Stainless Steel Model)	2	
53	HN04	HN, M4	2	
	HN04S	HN, M4 (Stainless Steel Model)	2	

4-2-2

FREE SLIDE ROLLER ASS'Y

T6-4-22000

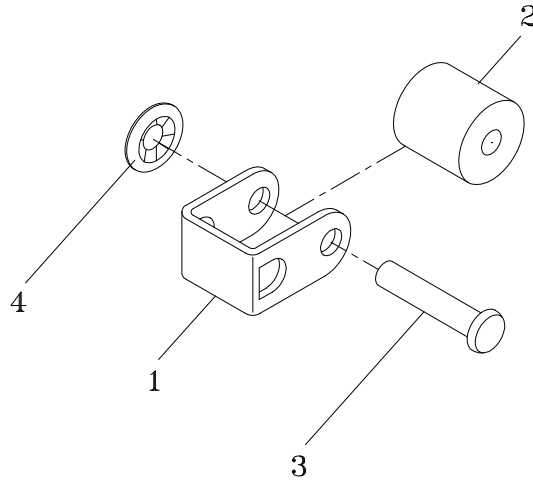

REF. NO.	PART NO.	DESCRIPTION	Q'TY	REMARKS
	T6-4-22000	Free Slide Roller Ass'y	1	
	T6-4-22000S	Free Slide Roller Ass'y (Stainless Steel Model)	1	
1	T6-4-22110	Free Slide Roller Bracket	1	
	T6-4-22110S	Free Slide Roller Bracket (Stainless Steel Model)	1	
2	TE-028	Roller	1	
3	T6-4-11140	Rivet, Ø6x30	1	
	T6-4-11140S	Rivet, Ø6x30 (Stainless Steel Model)	1	
4	PN06	PN, Ø6	1	
	PN06S	PN, Ø6 (Stainless Steel Model)	1	

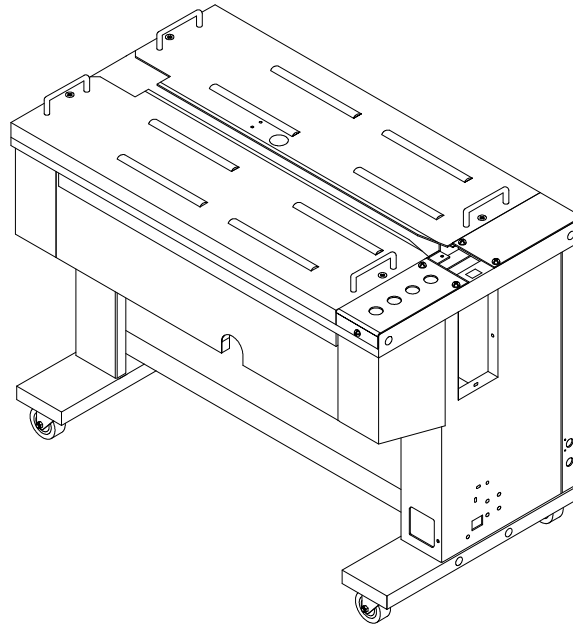

REF. NO.	PART NO.	DESCRIPTION	Q'TY	REMARKS
	T6-5-10054	Body Frame Group (For 850W)(For CE)	1	SEE PAGE 69
	T6-5-10054S	Body Frame Group (For 850W) (For CE)(Stainless Steel Model)	1	SEE PAGE 69
	T6-5-10101	Body Frame Group (For 850W) (For Non CE)	1	SEE PAGE 69
	T6-5-10101S	Body Frame Group (For 850W) (For Non CE)(Stainless Steel Model)	1	SEE PAGE 69
	T6-5-10055	Body Frame Group (For 1050W)(For CE)	1	SEE PAGE 69
	T6-5-10055S	Body Frame Group (For 1050W) (For CE)(Stainless Steel Model)	1	SEE PAGE 69
	T6-5-10102	Body Frame Group (For 1050W) (For Non CE)		SEE PAGE 69
	T6-5-10102S	Body Frame Group (For 1050W) (For Non CE)(Stainless Steel Model)	1	SEE PAGE 69
	T6-5-10056	Body Frame Group (For 1250W)(For CE)	1	SEE PAGE 69
	T6-5-10056S	Body Frame Group (For 1250W) (For CE)(Stainless Steel Model)	1	SEE PAGE 69
	T6-5-10103	Body Frame Group (For 1250W) (For Non CE)	1	SEE PAGE 69
	T6-5-10103S	Body Frame Group (For 1250W) (For Non CE)(Stainless Steel Model)	1	SEE PAGE 69

REF. NO.	PART NO.	DESCRIPTION	Q'TY	REMARKS
	T6-5-10057	Body Frame Group (For 1450W) (For CE)	1	SEE PAGE 69
	T6-5-10057S	Body Frame Group (For 1450W) (For CE)(Stainless Steel Model)	1	SEE PAGE 69
	T6-5-10104	Body Frame Group (For 1450W) (For Non CE)	1	SEE PAGE 69
	T6-5-10104S	Body Frame Group (For 1450W)(For Non CE)(Stainless Steel Model)	1	SEE PAGE 69
	T6-5-10058	Body Frame Group (For 1650W) (For CE)	1	SEE PAGE 69
	T6-5-10058S	Body Frame Group (For 1650W) (For CE)(Stainless Steel Model)	1	SEE PAGE 69
	T6-5-10105	Body Frame Group (For 1650W) (For Non CE)	1	SEE PAGE 69
	T6-5-10105S	Body Frame Group (For 1650W)(For Non CE)(Stainless Steel Model)	1	SEE PAGE 69
	T6-5-10059	Body Frame Group (For 1850W) (For CE)	1	SEE PAGE 69
	T6-5-10059S	Body Frame Group (For 1850W) (For CE)(Stainless Steel Model)	1	SEE PAGE 69
	T6-5-10106	Body Frame Group (For 1850W) (For Non CE)	1	SEE PAGE 69
	T6-5-10106S	Body Frame Group (For 1850W)(For Non CE)(Stainless Steel Model)	1	SEE PAGE 69
	T6-5-10029	Body Frame Group (For 650W) (For CE)	1	SEE PAGE 69
	T6-5-10029S	Body Frame Group (For 650W) (For CE)(Stainless Steel Model)	1	SEE PAGE 69
	T6-5-10107	Body Frame Group (For 650W) (For Non CE)	1	SEE PAGE 69
	T6-5-10107S	Body Frame Group (For 650W)(For Non CE)(Stainless Steel Model)	1	SEE PAGE 69

5

BODY FRAME GROUP

T6-5-10054

T6-5-10055

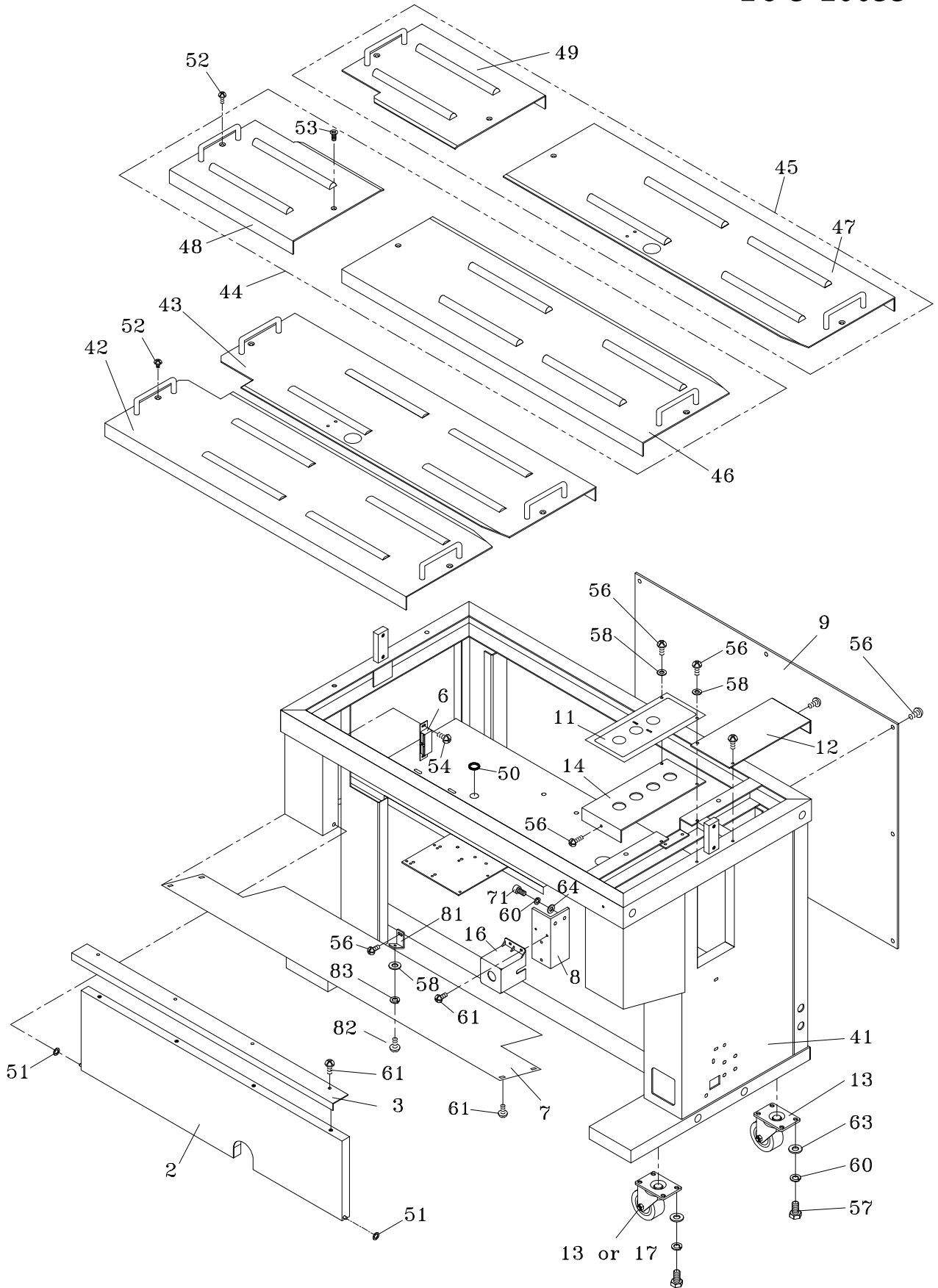

REF. NO.	PART NO.	DESCRIPTION	Q'TY	REMARKS
	T6-5-10054	Body Frame Group (For 850W) (For CE)	1	
	T6-5-10054S	Body Frame Group (For 850W) (For CE)(Stainless Steel Model)	1	
	T6-5-10101	Body Frame Group (For 850W) (For Non CE)	1	
	T6-5-10101S	Body Frame Group (For 850W)(For Non CE)(Stainless Steel Model)	1	
	T6-5-10055	Body Frame Group (For 1050W) (For CE)	1	
	T6-5-10055S	Body Frame Group (For 1050W) (For CE)(Stainless Steel Model)	1	
	T6-5-10102	Body Frame Group (For 1050W) (For Non CE)	1	
	T6-5-10102S	Body Frame Group (For 1050W)(For Non CE)(Stainless Steel Model)	1	
	T6-5-10056	Body Frame Group (For 1250W) (For CE)	1	
	T6-5-10056S	Body Frame Group (For 1250W) (For CE)(Stainless Steel Model)	1	
	T6-5-10103	Body Frame Group (For 1250W) (For Non CE)	1	
	T6-5-10103S	Body Frame Group (For 1250W)(For Non CE)(Stainless Steel Model)	1	
	T6-5-10057	Body Frame Group (For 1450W) (For CE)	1	
	T6-5-10057S	Body Frame Group (For 1450W) (For CE)(Stainless Steel Model)	1	
	T6-5-10104	Body Frame Group (For 1450W) (For Non CE)	1	
	T6-5-10104S	Body Frame Group (For 1450W)(For Non CE)(Stainless Steel Model)	1	
	T6-5-10058	Body Frame Group (For 1650W) (For CE)	1	
	T6-5-10058S	Body Frame Group (For 1650W) (For CE)(Stainless Steel Model)	1	

REF. NO.	PART NO.	DESCRIPTION	Q'TY	REMARKS
	T6-5-10105	Body Frame Group (For 1650W) (For Non CE)	1	
	T6-5-10105S	Body Frame Group (For 1650W)(For Non CE)(Stainless Steel Model)	1	
	T6-5-10059	Body Frame Group (For 1850W) (For CE)	1	
	T6-5-10059S	Body Frame Group (For 1850W) (For CE)(Stainless Steel Model)	1	
	T6-5-10106	Body Frame Group (For 1850W) (For Non CE)	1	
	T6-5-10106S	Body Frame Group (For 1850W)(For Non CE)(Stainless Steel Model)	1	
	T6-5-10029	Body Frame Group (For 650W) (For CE)	1	
	T6-5-10029S	Body Frame Group (For 650W) (For CE)(Stainless Steel Model)	1	
	T6-5-10107	Body Frame Group (For 650W) (For Non CE)	1	
	T6-5-10107S	Body Frame Group (For 650W)(For Non CE)(Stainless Steel Model)	1	
2	T6-5-10127	Front Door (For Non CE, Outside Tension)	1	
	T6-5-10127S	Front Door (For Non CE, Outside Tension)(Stainless Steel Model)	1	
	T6-5-10185	Front Door (For CE, Outside Tension)	1	
	T6-5-10185S	Front Door (For CE, Outside Tension) (Stainless Steel Model)	1	
3	T6-5-10130	Front Door Handle	1	
	T6-5-10130S	Front Door Handle (Stainless Steel Model)	1	
6	T6-5-10160	Magnet Catch	2	
7	T6-5-40009	Enclosed Bottom Plate (Only CE)	1	
	T6-5-40009S	Enclosed Bottom Plate (Only CE) (Stainless Steel Model)	1	
8	T6-5-40020	Power Switch Bracket (Only CE)	1	

REF. NO.	PART NO.	DESCRIPTION	Q'TY	REMARKS
9	T6-5-10190	Rear Plate	1	
	T6-5-10190S	Rear Plate (Stainless Steel Model)	1	
11	LA-10020	Control Label (For Non CE)	1	
	LA-10021	Control Label (For CE)	1	
12	T6-5-10220	Rear Cover	1	
	T6-5-10220S	Rear Cover (Stainless Steel Model)	1	
13	T6-5-10230	Caster (Free)(For 650W~1650W)	4	
		Caster (Free)(For 1850W)	6	
	T6-5-10231	Caster (Free)(Option)	2	
	T6-5-10232	Caster (Free)(For 650W~1650W) (Stainless Steel Model)	2	
		Caster (Free)(For 1850W) (Stainless Steel Model)	4	
14	T6-5-10244	Control Plate	1	
	T6-5-10244S	Control Plate (Stainless Steel Model)	1	
16	T6-5-10260	Cover (Only CE)	1	
17	T6-5-10270	Caster (Brake)(Option)	2	
	T6-5-10271	Caster (Brake)(Stainless Steel Model)	2	
41	T6-5-13005	Body Frame (For 850W)	1	
	T6-5-13005S	Body Frame (For 850W)(Stainless Steel Model)	1	
	T6-5-13006	Body Frame (For 650W)	1	
	T6-5-13006S	Body Frame (For 650W)(Stainless Steel Model)	1	
	T6-5-13007	Body Frame (For 1250W)	1	
	T6-5-13007S	Body Frame (For 1250W)(Stainless Steel Model)	1	
	T6-5-13008	Body Frame (For 1850W)	1	
	T6-5-13008S	Body Frame (For 1850W)(Stainless Steel Model)	1	
	T6-5-13010	Body Frame (For 1450W)	1	
	T6-5-13010S	Body Frame (For 1450W)(Stainless Steel Model)	1	
	T6-5-13011	Body Frame (For 1650W)	1	
	T6-5-13011S	Body Frame (For 1650W)(Stainless Steel Model)	1	

REF. NO.	PART NO.	DESCRIPTION	Q'TY	REMARKS
	T6-5-13015	Body Frame (For 1050W)	1	
	T6-5-13015S	Body Frame (For 1050W)(Stainless Steel Model)	1	
42	T6-5-11000	Upper Table, Front Ass'y (For 850W)	1	SEE PAGE 77
	T6-5-11000S	Upper Table, Front Ass'y (For 850W) (Stainless Steel Model)	1	SEE PAGE 77
	T6-5-11009	Upper Table, Front Ass'y (For 650W)	1	SEE PAGE 77
	T6-5-11009S	Upper Table, Front Ass'y (For 650W) (Stainless Steel Model)	1	SEE PAGE 77
43	T6-5-12000	Upper Table, Rear Ass'y (For 850W)	1	SEE PAGE 79
	T6-5-12000S	Upper Table, Rear Ass'y (For 850W) (Stainless Steel Model)	1	SEE PAGE 79
	T6-5-12009	Upper Table, Rear Ass'y (For 650W)	1	SEE PAGE 79
	T6-5-12009S	Upper Table, Rear Ass'y (For 650W) (Stainless Steel Model)	1	SEE PAGE 79
44	T6-5-11002	Upper Table, Front Ass'y (For 1050W)	1	
	T6-5-11002S	Upper Table, Front Ass'y (For 1050W) (Stainless Steel Model)	1	
	T6-5-11003	Upper Table, Front Ass'y (For 1250W)	1	
	T6-5-11003S	Upper Table, Front Ass'y (For 1250W) (Stainless Steel Model)	1	
	T6-5-11004	Upper Table, Front Ass'y (For 1450W)	1	
	T6-5-11004S	Upper Table, Front Ass'y (For 1450W) (Stainless Steel Model)	1	
	T6-5-11005	Upper Table, Front Ass'y (For 1650W)	1	
	T6-5-11005S	Upper Table, Front Ass'y (For 1650W) (Stainless Steel Model)	1	
	T6-5-11006	Upper Table, Front Ass'y (For 1850W)	1	
	T6-5-11006S	Upper Table, Front Ass'y (For 1850W) (Stainless Steel Model)	1	
45	T6-5-12006	Upper Table, Rear Ass'y (For 1050W)	1	
	T6-5-12006S	Upper Table, Rear Ass'y (For 1050W) (Stainless Steel Model)	1	
	T6-5-12007	Upper Table, Rear Ass'y (For 1250W)	1	
	T6-5-12007S	Upper Table, Rear Ass'y (For 1250W) (Stainless Steel Model)	1	

REF. NO.	PART NO.	DESCRIPTION	Q'TY	REMARKS
	T6-5-12008	Upper Table, Rear Ass'y (For 1450W)	1	
	T6-5-12008S	Upper Table, Rear Ass'y (For 1450W) (Stainless Steel Model)	1	
	T6-5-12012	Upper Table, Rear Ass'y (For 1650W)	1	
	T6-5-12012S	Upper Table, Rear Ass'y (For 1650W) (Stainless Steel Model)	1	
	T6-5-12013	Upper Table, Rear Ass'y (For 1850W)	1	
	T6-5-12013S	Upper Table, Rear Ass'y (For 1850W) (Stainless Steel Model)	1	
46	T6-5-10540	Upper Right Table, Front Set (For 1050W~1850W)	1	SEE PAGE 81
	T6-5-10540S	Upper Right Table, Front Set (For 1050W~1850W)(Stainless Steel Model)	1	SEE PAGE 81
47	T6-5-10582	Upper Right Table, Rear Set (For 1050W~1850W)	1	SEE PAGE 82
	T6-5-10582S	Upper Right Table, Rear Set (For 1050W~1850W)(Stainless Steel Model)	1	SEE PAGE 82
48	T6-5-10550	Upper Left Table, Front Set (For 1050W)	1	SEE PAGE 83
	T6-5-10550S	Upper Left Table, Front Set (For 1050W) (Stainless Steel Model)	1	SEE PAGE 83
	T6-5-10560	Upper Left Table, Front Set (For 1250W)	1	SEE PAGE 83
	T6-5-10560S	Upper Left Table, Front Set (For 1250W) (Stainless Steel Model)	1	SEE PAGE 83
	T6-5-10570	Upper Left Table, Front Set (For1450W)	1	SEE PAGE 83
	T6-5-10570S	Upper Left Table, Front Set (For1450W) (Stainless Steel Model)	1	SEE PAGE 83
	T6-5-10571	Upper Left Table, Front Set (For 1650W)	1	SEE PAGE 83
	T6-5-10571S	Upper Left Table, Front Set (For 1650W) (Stainless Steel Model)	1	SEE PAGE 83
	T6-5-10572	Upper Left Table, Front Set (For 1850W)	1	SEE PAGE 83
	T6-5-10572S	Upper Left Table, Front Set (For 1850W) (Stainless Steel Model)	1	SEE PAGE 83
49	T6-5-10590	Upper Left Table, Rear Set (For 1050W)	1	SEE PAGE 86
	T6-5-10590S	Upper Left Table, Rear Set (For 1050W) (Stainless Steel Model)	1	SEE PAGE 86

REF. NO.	PART NO.	DESCRIPTION	Q'TY	REMARKS
	T6-5-10600	Upper Left Table, Rear Set (For 1250W)	1	SEE PAGE 86
	T6-5-10600S	Upper Left Table, Rear Set (For 1250W) (Stainless Steel Model)	1	SEE PAGE 86
	T6-5-10850	Upper Left Table, Rear Set (For 1450W)	1	SEE PAGE 86
	T6-5-10850S	Upper Left Table, Rear Set (For 1450W) (Stainless Steel Model)	1	SEE PAGE 86
	T6-5-10851	Upper Left Table, Rear Set (For 1650W)	1	SEE PAGE 86
	T6-5-10851S	Upper Left Table, Rear Set (For 1650W) (Stainless Steel Model)	1	SEE PAGE 86
	T6-5-10852	Upper Left Table, Rear Set (For 1850W)	1	SEE PAGE 86
	T6-5-10852S	Upper Left Table, Rear Set (For 1850W) (Stainless Steel Model)	1	SEE PAGE 86
50	T6-5-10200	Grommet	1	
51	T6-5-10250	Nylon Washer	2	
52	TMS0615S	TMS, M6x15 (SUS)	4	
53	FMS0615S	FMS, M6x15 (SUS)(For 1050W~1850W)	4	
54	TMS0308	TMS, M3x8	2	
56	TMS0508	TMS, M5x8	15	
	TMS0508S	TMS, M5x8 (Stainless Steel Model)	15	
57	HB0616	HB, M6x16	16	
	HB0616S	HB, M6x16 (Stainless Steel Model)	16	
58	PW05	PW, M5 (For CE)	3	
		PW, M5 (For Non CE)	2	
	PW05S	PW, M5 (For CE)(Stainless Steel Model)	3	
		PW, M5 (For Non CE)(Stainless Steel)	2	
60	SW06	SW, M6 (For CE)	18	
		SW, M6 (For Non CE)	16	
	SW06S	SW, M6 (For CE)(Stainless Steel Model)	18	
		PW, M5 (For Non CE)(Stainless Steel Model)	16	
61	TMS0408	TMS, M4x8 (For Non CE)	8	
		TMS, M4x8 (For CE)	10	
	TMS0408S	TMS, M4x8 (For Non CE) (Stainless Steel Model)	8	
		TMS, M4x8 (For CE) (Stainless Steel Model)	10	

REF. NO.	PART NO.	DESCRIPTION	Q'TY	REMARKS
63	PW06C	PW, M6	16	
	PW06CS	PW, M6 (C)(Stainless Steel Model)	16	
64	PW06A	PW, M6 (A)(Only CE)	2	
	PW06AS	PW, M6 (A)(Only CE)(Stainless Steel Model)	2	
71	HBS0612	HBS, M6x12 (Only CE)	2	
	HBS0612S	HBS, M6x12 (Only CE) (Stainless Steel Model)	2	
81	T6-5-10910	Bracket (Only CE)	1	
	T6-5-10910S	Bracket (Only CE)(Stainless Steel Model)	1	
82	TMS0512	TMS, M5x12 (Only CE)	1	
	TMS0512S	TMS, M5x12 (Only CE) (Stainless Steel Model)	1	
83	SW05	SW, M5 (Only CE)	1	
	SW05S	SW, M5 (Only CE)(Stainless Steel Model)	1	

5-1

UPPER TABLE, FRONT ASS'Y

T6-5-11000

T6-5-11009

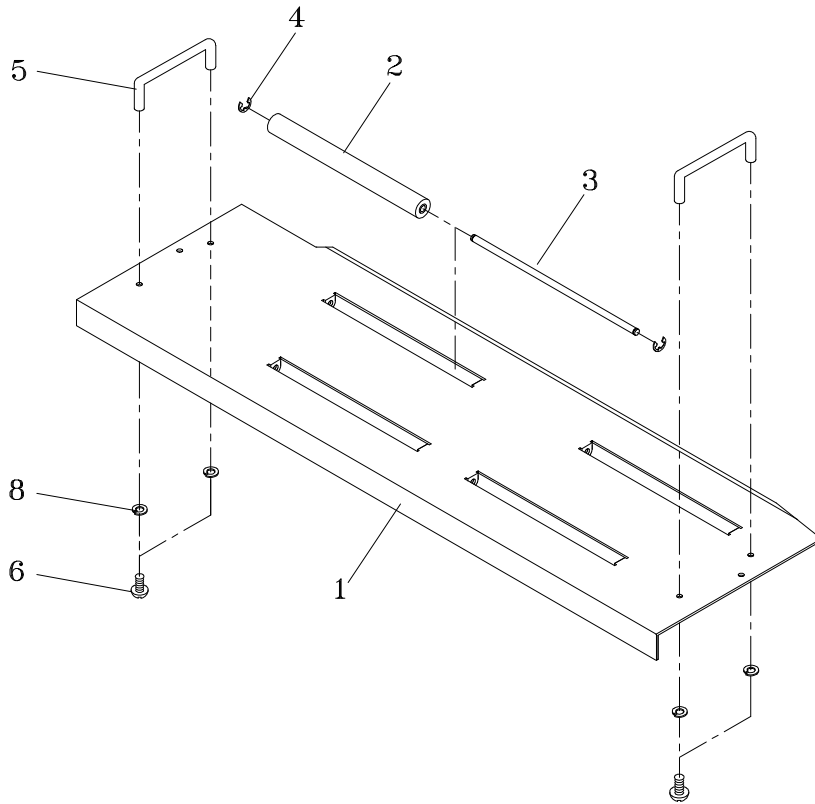

REF. NO.	PART NO.	DESCRIPTION	Q'TY	REMARKS	
1	T6-5-11000	Upper Table, Front Ass'y (For 850W)	1		
	T6-5-11000S	Upper Table, Front Ass'y (For 850W) (Stainless Steel Model)	1		
	T6-5-11009	Upper Table, Front Ass'y (For 650W)	1		
	T6-5-11009S	Upper Table, Front Ass'y (For 650W) (Stainless Steel Model)	1		
	T6-5-11110	Upper Table Front (For 850W)	1		
	T6-5-11110S	Upper Table Front (For 850W) (Stainless Steel Model)	1		
	T6-5-11010	Upper Table Front (For 650W)	1		
	T6-5-11010S	Upper Table Front (For 650W) (Stainless Steel Model)	1		
	2	T6-5-11120	Table Roller	4	
		T6-5-11121	Table Roller (Stainless Steel Model)	4	
3	T6-5-11130	Table Roller Shaft	4		
	T6-5-11131	Table Roller Shaft (Stainless Steel Model)	4		

5-1**UPPER TABLE, FRONT ASS'Y****T6-5-11000****T6-5-11009**

REF. NO.	PART NO.	DESCRIPTION	Q'TY	REMARKS
4	ER07	Snap Ring, E-7	8	
	ER07S	Snap Ring, E-7 (Stainless Steel Model)	8	
5	T6-5-11150	Table Handle	2	
	T6-5-11150S	Table Handle (Stainless Steel Model)	2	
6	TMS0612	TMS, M6x12	4	
	TMS0612S	TMS, M6x12 (Stainless Steel Model)	4	
8	SW06	SW, M6	4	
	SW06S	SW, M6 (Stainless Steel Model)	4	

5-2

UPPER TABLE, REAR ASS'Y

**T6-5-12000
T6-5-12009**

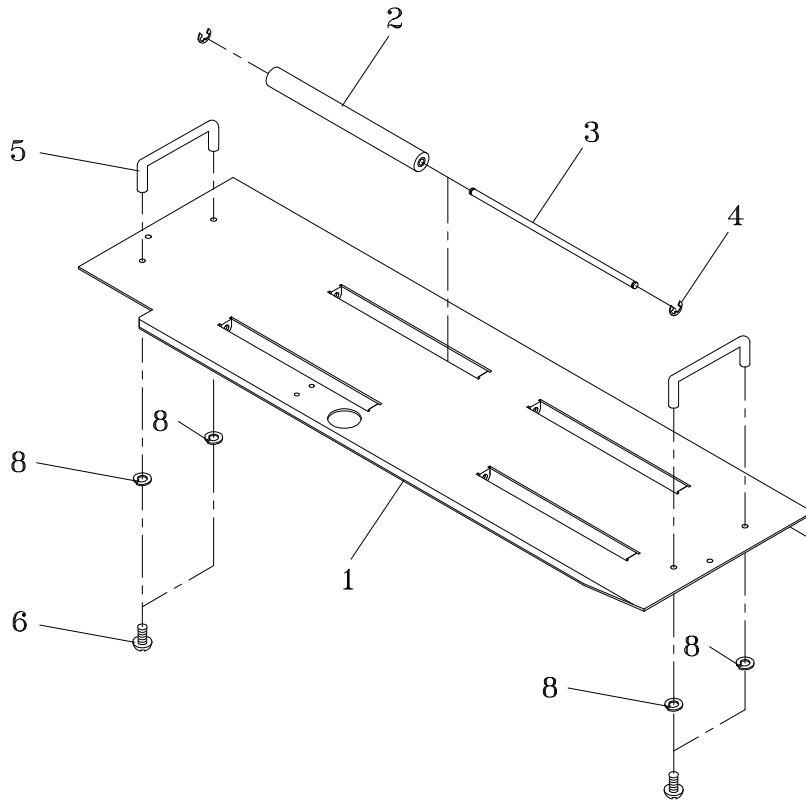

REF. NO.	PART NO.	DESCRIPTION	Q'TY	REMARKS
	T6-5-12000	Upper Table, Rear Ass'y (For 850W)	1	
	T6-5-12000S	Upper Table, Rear Ass'y (For 850W) (Stainless Steel Model)	1	
	T6-5-12009	Upper Table, Rear Ass'y (For 650W)	1	
	T6-5-12009S	Upper Table, Rear Ass'y (For 650W) (Stainless Steel Model)	1	
1	T6-5-12110	Upper Rear (For 850W)	1	
	T6-5-12110S	Upper Rear (Stainless Steel Model) (For 850W)	1	
	T6-5-12010	Upper Rear (For 650W)	1	
	T6-5-12010S	Upper Rear (Stainless Steel Model) (For 650W)	1	
2	T6-5-11120	Table Roller	4	
	T6-5-11121	Table Roller (Stainless Steel Model)	4	
3	T6-5-11130	Table Roller Shaft	4	
	T6-5-11131	Table Roller Shaft (Stainless Steel Model)	4	
4	ER07	Snap Ring, E-7	8	
	ER07S	Snap Ring, E-7 (Stainless Steel Model)	8	

5-2

UPPER TABLE, REAR ASS'Y

T6-5-12000

T6-5-12009

REF. NO.	PART NO.	DESCRIPTION	Q'TY	REMARKS
5	T6-5-11150	Table Handle	2	
	T6-5-11150S	Table Handle (Stainless Steel Model)	2	
6	TMS0612	TMS, M6x12	4	
	TMS0612S	TMS, M6x12 (Stainless Steel Model)	4	
8	SW06	SW, M6	4	
	SW06S	SW, M6 (Stainless Steel Model)	4	

5-3

**UPPER RIGHT TABLE,
FRONT SET
(For 1050W~1850W)**

T6-5-10540

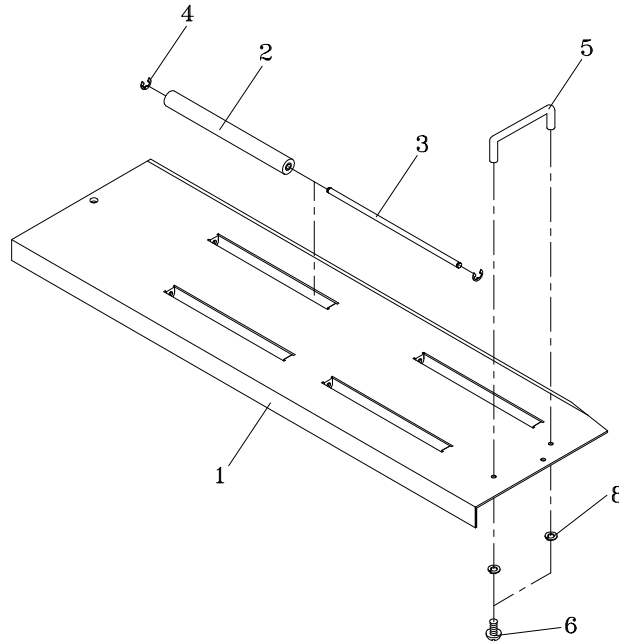

REF. NO.	PART NO.	DESCRIPTION	Q'TY	REMARKS
	T6-5-10540	Upper Right Table, Front Set (For 1050W~1850W)	1	
	T6-5-10540S	Upper Right Table, Front Set (For 1050W~1850W)(Stainless Steel Model)	1	
1	T6-5-11020	Upper Right Table Front (For 1050W~1850W)	1	
	T6-5-11020S	Upper Right Table Front (For 1050W~ 1850W) (Stainless Steel Model)		
2	T6-5-11120	Table Roller	4	
	T6-5-11121	Table Roller (Stainless Steel Model)	4	
3	T6-5-11130	Table Roller Shaft	4	
	T6-5-11131	Table Roller Shaft (Stainless Steel Model)	4	
4	ER07	Snap Ring, E-7	8	
	ER07S	Snap Ring, E-7 (Stainless Steel Model)	8	
5	T6-5-11150	Table Handle	1	
	T6-5-11150S	Table Handle (Stainless Steel Model)	1	
6	TMS0612	TMS, M6x12	2	
	TMS0612S	TMS, M6x12 (Stainless Steel Model)	2	
8	SW06	SW, M6	2	
	SW06S	SW, M6 (Stainless Steel Model)	2	

5-4

**UPPER RIGHT TABLE,
REAR SET
(For 1050W~1850W)**

T6-5-10582

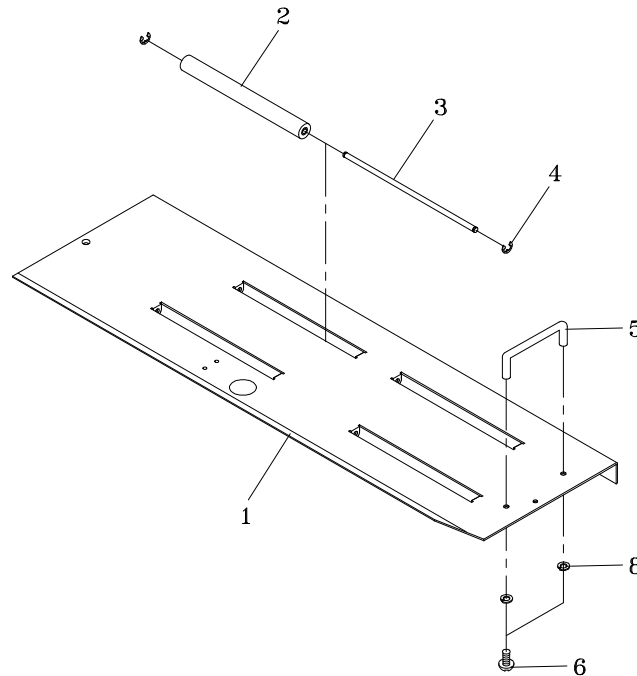

REF. NO.	PART NO.	DESCRIPTION	Q'TY	REMARKS
	T6-5-10582	Upper Right Table, Rear Set (For 1050W~1850W)	1	
	T6-5-10582S	Upper Right Table, Rear Set (For 1050W~1850W)(Stainless Steel Model)	1	
1	T6-5-12022	Upper Right Rear (For 1050~1850W)	1	
	T6-5-12022S	Upper Right Rear (Stainless Steel Model) (For 1050~1850W)	1	
2	T6-5-11120	Table Roller	4	
	T6-5-11121	Table Roller (Stainless Steel Model)	4	
3	T6-5-11130	Table Roller Shaft	4	
	T6-5-11131	Table Roller Shaft (Stainless Steel Model)	4	
4	ER07	Snap Ring, E-7	8	
	ER07S	Snap Ring, E-7 (Stainless Steel Model)	8	
5	T6-5-11150	Table Handle	1	
	T6-5-11150S	Table Handle (Stainless Steel Model)	1	
6	TMS0612	TMS, M6x12	2	
	TMS0612S	TMS, M6x12 (Stainless Steel Model)	2	
8	SW06	SW, M6	2	
	SW06S	SW, M6 (Stainless Steel Model)	2	

5-5 UPPER LEFT TABLE, FRONT SET T6-5-10550 T6-5-10560

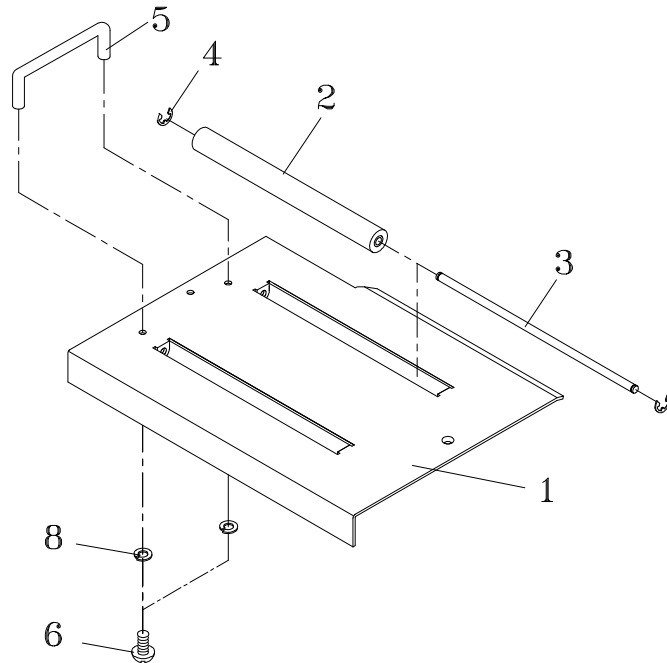

REF. NO.	PART NO.	DESCRIPTION	Q'TY	REMARKS
	T6-5-10550	Upper Left Table, Front Set (For 1050W)	1	
	T6-5-10550S	Upper Left Table, Front Set (For 1050W) (Stainless Steel Model)	1	
	T6-5-10560	Upper Left Table, Front Set (For 1250W)	1	
	T6-5-10560S	Upper Left Table, Front Set (For 1250W) (Stainless Steel Model)	1	
	T6-5-10570	Upper Left Table, Front Set (For 1450W)	1	
	T6-5-10570S	Upper Left Table, Front Set (For 1450W) (Stainless Steel Model)	1	
	T6-5-10571	Upper Left Table, Front Set (For 1650W)	1	
	T6-5-10571S	Upper Left Table, Front Set (For 1650W) (Stainless Steel Model)	1	
	T6-5-10572	Upper Left Table, Front Set (For 1850W)	1	
	T6-5-10572S	Upper Left Table, Front Set (For 1850W) (Stainless Steel Model)	1	

5-5

UPPER LEFT TABLE, FRONT SET

T6-5-10550

T6-5-10560

REF. NO.	PART NO.	DESCRIPTION	Q'TY	REMARKS	
1	T6-5-11030	Upper Left Table Front (For 1050W)	1		
	T6-5-11030S	Upper Left Table Front (For 1050W) (Stainless Steel Model)	1		
	T6-5-11040	Upper Left Table Front (For 1250W)	1		
	T6-5-11040S	Upper Left Table Front (For 1250W) (Stainless Steel Model)	1		
	T6-5-11050	Upper Left Table Front (For 1450W)	1		
	T6-5-11050S	Upper Left Table Front (For 1450W) (Stainless Steel Model)	1		
	T6-5-11060	Upper Left Table Front (For 1650W)	1		
	T6-5-11060S	Upper Left Table Front (For 1650W) (Stainless Steel Model)	1		
	T6-5-11070	Upper Left Table Front (For 1850W)	1		
	T6-5-11070S	Upper Left Table Front (For 1850W) (Stainless Steel Model)	1		
	2	T6-5-11120	Table Roller (For 1250/1450W)	2	
			Table Roller (For 1650/1850W)	4	
		T6-5-11121	Table Roller (For 1250/1450W) (Stainless Steel Model)	2	
			Table Roller (For 1650/1850W) (Stainless Steel Model)	4	
3	T6-5-11130	Table Roller Shaft (For 1250/1450W)	2		
		Table Roller Shaft (For 1650/1850W)	4		
	T6-5-11131	Table Roller Shaft (For 1250/1450W) (Stainless Steel Model)	2		
		Table Roller Shaft (For 1650/1850W) (Stainless Steel Model)	4		
4	ER07	Snap Ring, E-7 (For 1250/1450W)	4		
		Snap Ring, E-7 (For 1650/1850W)	8		
	ER07S	Snap Ring, E-7 (For 1250/1450W) (Stainless Steel Model)	4		
		Snap Ring, E-7 (For 1650/1850W) (Stainless Steel Model)	8		
5	T6-5-11150	Table Handle	1		
	T6-5-11150S	Table Handle (Stainless Steel Model)	1		

5-5

UPPER LEFT TABLE, FRONT SET

T6-5-10550

T6-5-10560

REF. NO.	PART NO.	DESCRIPTION	Q'TY	REMARKS
6	TMS0612	TMS, M6x12	2	
	TMS0612S	TMS, M6x12 (Stainless Steel Model)	2	
8	SW06	SW, M6	2	
	SW06S	SW, M6 (Stainless Steel Model)	2	

5-6 UPPER LEFT TABLE, REAR SET T6-5-10590 T6-5-10600

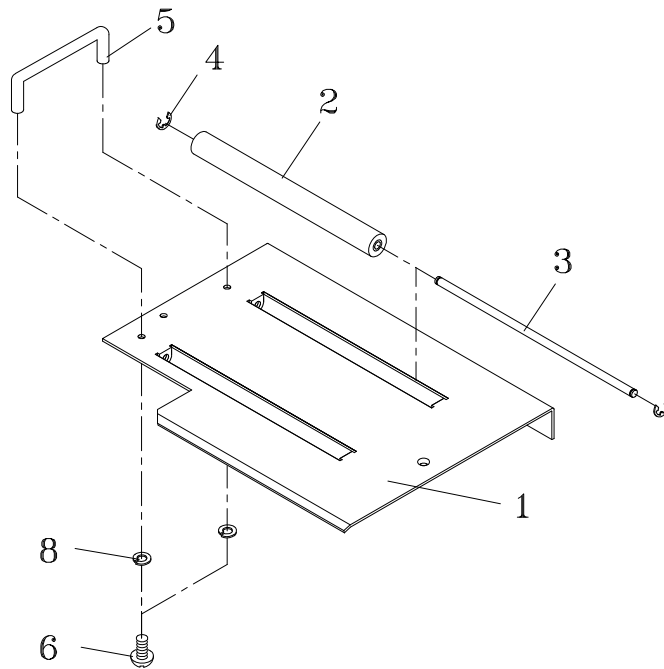

REF. NO.	PART NO.	DESCRIPTION	Q'TY	REMARKS
	T6-5-10590	Upper Left Table, Rear Set (For 1050W)	1	
	T6-5-10590S	Upper Left Table, Rear Set (For 1050W) (Stainless Steel Model)	1	
	T6-5-10600	Upper Left Table, Rear Set (For 1250W)	1	
	T6-5-10600S	Upper Left Table, Rear Set (For 1250W) (Stainless Steel Model)	1	
	T6-5-10850	Upper Left Table, Rear Set (For 1450W)	1	
	T6-5-10850S	Upper Left Table, Rear Set (For 1450W) (Stainless Steel Model)	1	
	T6-5-10851	Upper Left Table, Rear Set (For 1650W)	1	
	T6-5-10851S	Upper Left Table, Rear Set (For 1650W) (Stainless Steel Model)	1	
	T6-5-10852	Upper Left Table, Rear Set (For 1850W)	1	
	T6-5-10852S	Upper Left Table, Rear Set (For 1850W) (Stainless Steel Model)	1	

5-6

UPPER LEFT TABLE, REAR SET

T6-5-10590

T6-5-10600

REF. NO.	PART NO.	DESCRIPTION	Q'TY	REMARKS	
1	T6-5-12030	Upper Left Table Rear (For 1050W)	1		
	T6-5-12030S	Upper Left Table Rear (For 1050W) (Stainless Steel Model)	1		
	T6-5-12040	Upper Left Table Rear (For 1250W)	1		
	T6-5-12040S	Upper Left Table Rear (For 1250W) (Stainless Steel Model)	1		
	T6-5-12050	Upper Left Table Rear (For 1450W)	1		
	T6-5-12050S	Upper Left Table Rear (For 1450W) (Stainless Steel Model)	1		
	T6-5-12060	Upper Left Table Rear (For 1650W)	1		
	T6-5-12060S	Upper Left Table Rear (For 1650W) (Stainless Steel Model)	1		
	T6-5-12070	Upper Left Table Rear (For 1850W)	1		
	T6-5-12070S	Upper Left Table Rear (For 1850W) (Stainless Steel Model)	1		
	2	T6-5-11120	Table Roller (For 1250/1450W)	2	
			Table Roller (For 1650/1850W)	4	
		T6-5-11121	Table Roller (For 1250/1450W) (Stainless Steel Model)	2	
			Table Roller (For 1650/1850W) (Stainless Steel Model)	4	
3	T6-5-11130	Table Roller Shaft (For 1250/1450W)	2		
		Table Roller Shaft (For 1650/1850W)	4		
	T6-5-11131	Table Roller Shaft (For 1250/1450W) (Stainless Steel Model)	2		
		Table Roller Shaft (For 1650/1850W) (Stainless Steel Model)	4		
4	ER07	Snap Ring, E-7 (For 1250/1450W)	4		
		Snap Ring, E-7 (For 1650/1850W)	8		
	ER07S	Snap Ring, E-7 (For 1250/1450W) (Stainless Steel Model)	4		
		Snap Ring, E-7 (For 1650/1850W) (Stainless Steel Model)	8		
5	T6-5-11150	Table Handle	1		
	T6-5-11150S	Table Handle (Stainless Steel Model)	1		

5-6

UPPER LEFT TABLE, REAR SET

T6-5-10590

T6-5-10600

REF. NO.	PART NO.	DESCRIPTION	Q'TY	REMARKS
6	TMS0612	TMS, M6x12	2	
	TMS0612S	TMS, M6x12 (Stainless Steel Model)	2	
8	SW06	SW, M6	2	
	SW06S	SW, M6 (Stainless Steel Model)	2	

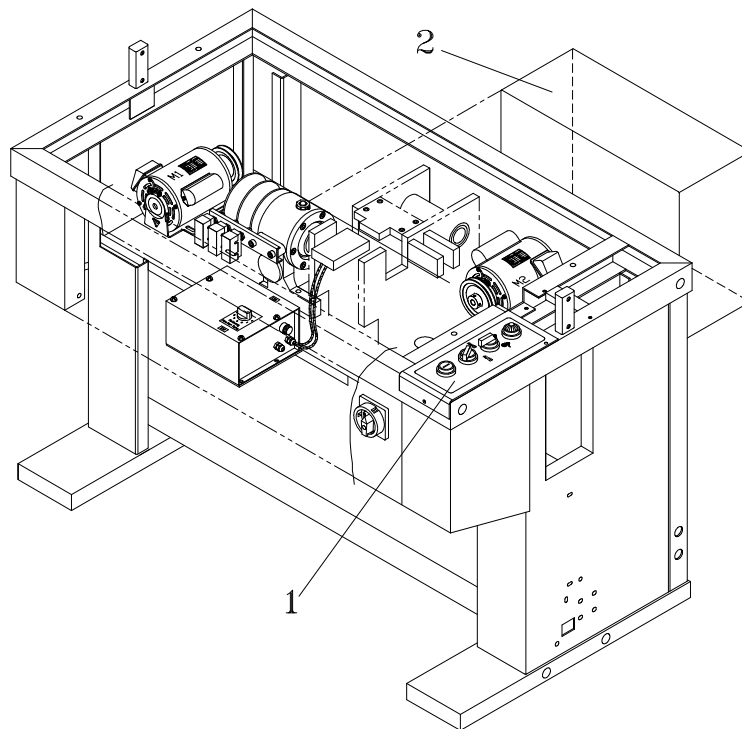

REF. NO.	PART NO.	DESCRIPTION	Q'TY	REMARKS
	T6-6-90010	Electric Control Unit (For TP-6000-1, 220V, 1PH)	1	
	T6-6-90010S	Electric Control Unit (For TP-6000-1, 220V, 1PH) (Stainless Steel Model)	1	
	T6-6-90011	Electric Control Unit (For TP-6000CE1, 220V, 1PH)	1	
	T6-6-90011S	Electric Control Unit (For TP-6000CE1, 220V, 1PH) (Stainless Steel Model)	1	
	T6-6-90012	Electric Control Unit (For TP-6000-1, 110V, 1PH)	1	
	T6-6-90012S	Electric Control Unit (For TP-6000-1, 110V, 1PH) (Stainless Steel Model)	1	
	T6-6-90013	Electric Control Unit (For TP-6000CE1, 110V, 1PH)	1	
	T6-6-90013S	Electric Control Unit (For TP-6000CE1, 110V, 1PH) (Stainless Steel Model)	1	
	T6-6-90014	Electric Control Unit (For TP-6000-1, 240V, 1PH)	1	
	T6-6-90014S	Electric Control Unit (For TP-6000-1, 240V, 1PH) (Stainless Steel Model)	1	
	T6-6-90015	Electric Control Unit (For TP-6000CE1, 240V, 1PH)	1	
	T6-6-90015S	Electric Control Unit (For TP-6000CE1, 240V, 1PH) (Stainless Steel Model)	1	

REF. NO.	PART NO.	DESCRIPTION	Q'TY	REMARKS
	T6-6-90016	Electric Control Unit (For TP-6000-3, 220V, 3PH)	1	
	T6-6-90016S	Electric Control Unit (For TP-6000-3, 220V, 3PH)(Stainless Steel Model)	1	
	T6-6-90017	Electric Control Unit (For TP-6000CE3, 220V, 3PH)	1	
	T6-6-90017S	Electric Control Unit (For TP-6000CE3, 220V, 3PH)(Stainless Steel Model)	1	
	T6-6-90018	Electric Control Unit (For TP-6000-3, 380V, 3PH)	1	
	T6-6-90018S	Electric Control Unit (For TP-6000-3, 380V, 3PH)(Stainless Steel Model)	1	
	T6-6-90019	Electric Control Unit (For TP-6000CE3, 380V, 3PH)	1	
	T6-6-90019S	Electric Control Unit (For TP-6000CE3, 380V, 3PH)(Stainless Steel Model)	1	
	T6-6-90020	Electric Control Unit (For TP-6000-3, 415V, 3PH)	1	
	T6-6-90020S	Electric Control Unit (For TP-6000-3, 415V, 3PH)(Stainless Steel Model)	1	
	T6-6-90021	Electric Control Unit (For TP-6000CE3, 415V, 3PH)	1	
	T6-6-90021S	Electric Control Unit (For TP-6000CE3, 415V, 3PH)(Stainless Steel Model)	1	
1	T6-6-10035	Electric Control Group (For TP-6000-1, 220V, 1PH)	1	SEE PAGE 93
	T6-6-10035S	Electric Control Group (For TP-6000-1, 220V, 1PH)(Stainless Steel Model)	1	SEE PAGE 93
	T6-6-10036	Electric Control Group (For TP-6000CE1, 220V, 1PH)	1	SEE PAGE 93
	T6-6-10036S	Electric Control Group (For TP-6000CE1, 220V, 1PH)(Stainless Steel Model)	1	SEE PAGE 93
	T6-6-10037	Electric Control Group (For TP-6000-1, 110V, 1PH)	1	SEE PAGE 93
	T6-6-10037S	Electric Control Group (For TP-6000-1, 110V, 1PH)(Stainless Steel Model)	1	SEE PAGE 93

REF. NO.	PART NO.	DESCRIPTION	Q'TY	REMARKS
	T6-6-10038	Electric Control Group (For TP-6000CE1, 110V, 1PH)	1	SEE PAGE 93
	T6-6-10038S	Electric Control Group (For TP-6000CE1, 110V, 1PH)(Stainless Steel Model)	1	SEE PAGE 93
	T6-6-10039	Electric Control Group (For TP-6000-1, 240V, 1PH)	1	SEE PAGE 93
	T6-6-10039S	Electric Control Group (For TP-6000-1, 240V, 1PH)(Stainless Steel Model)	1	SEE PAGE 93
	T6-6-10040	Electric Control Group (For TP-6000CE1, 240V, 1PH)	1	SEE PAGE 93
	T6-6-10040S	Electric Control Group (For TP-6000CE1, 240V, 1PH)(Stainless Steel Model)	1	SEE PAGE 93
	T6-6-10041	Electric Control Group (For TP-6000-3, 220V, 3PH)	1	SEE PAGE 93
	T6-6-10041S	Electric Control Group (For TP-6000-3, 220V, 3PH)(Stainless Steel Model)	1	SEE PAGE 93
	T6-6-10042	Electric Control Group (For TP-6000CE3, 220V, 3PH)	1	SEE PAGE 93
	T6-6-10042S	Electric Control Group (For TP-6000CE3, 220V, 3PH)(Stainless Steel Model)	1	SEE PAGE 93
	T6-6-10043	Electric Control Group (For TP-6000-3, 380V, 3PH)	1	SEE PAGE 93
	T6-6-10043S	Electric Control Group (For TP-6000-3, 380V, 3PH)(Stainless Steel Model)	1	SEE PAGE 93
	T6-6-10044	Electric Control Group (For TP-6000CE3, 380V, 3PH)	1	SEE PAGE 93
	T6-6-10044S	Electric Control Group (For TP-6000CE3, 380V, 3PH)(Stainless Steel Model)	1	SEE PAGE 93
	T6-6-10045	Electric Control Group (For TP-6000-3, 415V, 3PH)	1	SEE PAGE 93
	T6-6-10045S	Electric Control Group (For TP-6000-3, 415V, 3PH)(Stainless Steel Model)	1	SEE PAGE 93
	T6-6-10046	Electric Control Group (For TP-6000CE3, 415V, 3PH)	1	SEE PAGE 93
	T6-6-10046S	Electric Control Group (For TP-6000CE3, 415V, 3PH)(Stainless Steel Model)	1	SEE PAGE 93

REF. NO.	PART NO.	DESCRIPTION	Q'TY	REMARKS
2	T6-6-30025	Electric Control Group (For TP-6000-1, 220V/230V/240V)	1	SEE PAGE 100
	T6-6-30026	Electric Control Group (For TP-6000-1, 110V)	1	SEE PAGE 100
	T6-6-40034	Electric Control Group (For TP-6000CE1, 220V/230V/240V)	1	SEE PAGE 100
	T6-6-40035	Electric Control Group (For TP-6000CE1, 110V)	1	SEE PAGE 100
	T6-6-50001	Electric Control Group (For TP-6000-3)	1	SEE PAGE 103
	T6-6-50002	Electric Control Group (For TP-6000CE3)	1	SEE PAGE 103

6-1

ELECTRIC CONTROL GROUP

T6-6-10035

T6-6-10036

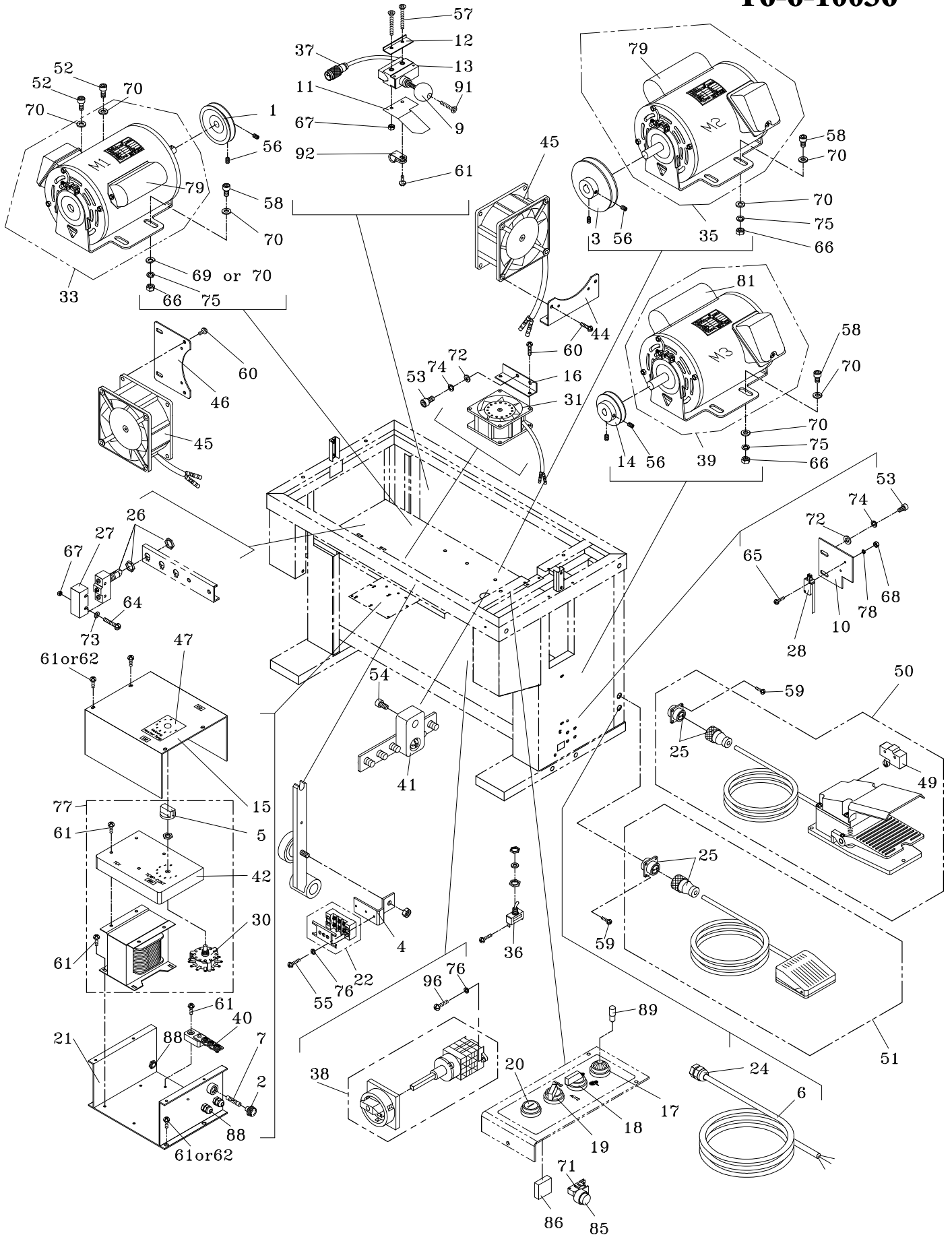

REF. NO.	PART NO.	DESCRIPTION	Q'TY	REMARKS
	T6-6-10035	Electric Control Group (For TP-6000-1, 220V, 1PH)	1	
	T6-6-10035S	Electric Control Group (For TP-6000-1, 220V, 1PH)(Stainless Steel Model)	1	
	T6-6-10036	Electric Control Group (For TP-6000CE1, 220V, 1PH)	1	
	T6-6-10036S	Electric Control Group (For TP-6000CE1, 220V, 1PH)(Stainless Steel Model)	1	
	T6-6-10037	Electric Control Group (For TP-6000-1, 110V, 1PH)	1	
	T6-6-10037S	Electric Control Group (For TP-6000-1, 110V, 1PH)(Stainless Steel Model)	1	
	T6-6-10038	Electric Control Group (For TP-6000CE1, 110V, 1PH)	1	
	T6-6-10038S	Electric Control Group (For TP-6000CE1, 110V, 1PH)(Stainless Steel Model)	1	
	T6-6-10039	Electric Control Group (For TP-6000-1, 240V, 1PH)	1	
	T6-6-10039S	Electric Control Group (For TP-6000-1, 240V, 1PH)(Stainless Steel Model)	1	
	T6-6-10040	Electric Control Group (For TP-6000CE1, 240V, 1PH)	1	
	T6-6-10040S	Electric Control Group (For TP-6000CE1, 240V, 1PH)(Stainless Steel Model)	1	
	T6-6-10041	Electric Control Group (For TP-6000-3, 220V, 3PH)	1	
	T6-6-10041S	Electric Control Group (For TP-6000-3, 220V, 3PH)(Stainless Steel Model)	1	
	T6-6-10042	Electric Control Group (For TP-6000CE3, 220V, 3PH)	1	
	T6-6-10042S	Electric Control Group (For TP-6000CE3, 220V, 3PH)(Stainless Steel Model)	1	
	T6-6-10043	Electric Control Group (For TP-6000-3, 380V, 3PH)	1	
	T6-6-10043S	Electric Control Group (For TP-6000-3, 380V, 3PH)(Stainless Steel Model)	1	

REF. NO.	PART NO.	DESCRIPTION	Q'TY	REMARKS
	T6-6-10044	Electric Control Group (For TP-6000CE3, 380V, 3PH)	1	
	T6-6-10044S	Electric Control Group (For TP-6000CE3, 380V, 3PH)(Stainless Steel Model)	1	
	T6-6-10045	Electric Control Group (For TP-6000-3, 415V, 3PH)	1	
	T6-6-10045S	Electric Control Group (For TP-6000-3, 415V, 3PH)(Stainless Steel Model)	1	
	T6-6-10046	Electric Control Group (For TP-6000CE3, 415V, 3PH)	1	
	T6-6-10046S	Electric Control Group (For TP-6000CE3, 415V, 3PH)(Stainless Steel Model)	1	
1	T6-6-10110	Motor (M1) Pulley (For 3PH)	1	
	T6-6-30002	Motor (M1) Pulley (For 1PH)	1	
2	TG-013	Fuse Holder	1	
3	T6-6-10130	Motor (M2) Pulley (For 3PH)	1	
	T6-6-30005	Motor (M2) Pulley (For 1PH)	1	
4	T6-6-10140	Heater Terminal Bracket	1	
5	TF-025	Knob	1	
6	T6-6-10161	Power Cord (Europe Plug)(For 1PH)	1	
	T6-6-10162	Power Cord (America Plug)(For 1PH)	1	
	T6-6-10163	Power Cord (For 3PH)	1	
7	T6-6-40007	Fuse 15A	1	
9	T6-6-10190	Limit Switch Ball	1	
10	T6-6-10200	Limit Switch Base	1	
11	T6-6-10210	Limit Switch Fixing Plate	1	
12	T6-6-10220	Limit Switch Cover	1	
13	T6-6-10230	ML, Limit Switch	1	
14	T6-1-71160	Feed Roller Pulley	1	
15	T6-6-40002	Transformer Box Cover	1	
	T6-6-40002S	Transformer Box Cover (Stainless Steel Model)	1	
16	T6-6-10260	Smoke Fan Bracket	1	

REF. NO.	PART NO.	DESCRIPTION	Q'TY	REMARKS
17	T6-6-30011	Power Selector Switch (For Non CE)	1	
	T6-6-40018	Power Light (For CE)	1	
	T6-6-10301	Start Switch With Lamp (For CE, S.F.S.)(Option)	1	
18	T6-6-30010	Auto-return Selector Switch	1	
19	T6-6-30009	Stop Switch 1NC (For Non CE)	1	
	T6-6-40016	2P. Selector Switch (For CE)	1	
20	T6-6-30008	Mushroom Head Switch (Start) (For Non CE)	1	
	T6-6-40015	Push Button Switch (Start, Reset) (For CE)	1	
	T6-6-10301	Start Switch With Lamp (For S.F.S) (Option)	1	
21	T6-6-40006	Transformer Box	1	
	T6-6-40006S	Transformer Box (Stainless Steel Model)	1	
22	T6-6-10320	Heater Terminal	1	
24	T6-6-10340	Cable Gland (PG13.5)	1	
25	T6-6-10350	Foot Switch Consent	1	
26	T6-6-10360	Limit Switch (LS1-3)	3	
27	T6-6-10370	Limit Switch Cover (LS1-3)	3	
28	T6-6-10380	Limit Switch (LS4)	1	
30	TF-027	Selector Switch	1	
31	TF-021	Fan (Only 110V)	1	
	TF-021-1	Fan	1	
33	T6-6-30060	Motor (M1)(For 220V, 1PH)	1	
	T6-6-30051	Motor (M1)(For 110V, 1PH)	1	
	T6-6-30052	Motor (M1)(For 240V, 1PH)	1	
	T6-6-10442	Motor (M1)(For 220V, 3PH)	1	
	T6-6-10444	Motor (M1)(For 380V, 3PH)	1	
	T6-6-10441	Motor (M1)(For 415V, 3PH)	1	
35	T6-6-30070	Motor (M2)(For 220V, 1PH)	1	
	T6-6-30054	Motor (M2)(For 110V, 1PH)	1	
	T6-6-30055	Motor (M2)(For 240V, 1PH)	1	

REF. NO.	PART NO.	DESCRIPTION	Q'TY	REMARKS
	T6-6-10442	Motor (M2)(For 220V, 3PH)	1	
	T6-6-10444	Motor (M2)(For 380V, 3PH)	1	
	T6-6-10441	Motor (M2)(For 415V, 3PH)	1	
36	T6-6-10460	Snap Switch (Only Non CE)	1	
37	T6-6-40023	Switch Connector (Only CE)	1	
38	T6-6-40040	Main Power Switch (Only CE)	1	
39	T6-6-30080	Motor (M3)(For 220V, 1PH)	1	
	T6-6-30057	Motor (M3)(For 110V, 1PH)	1	
	T6-6-30058	Motor (M3)(For 240V, 1PH)	1	
	T6-6-10442	Motor (M3)(For 220V, 3PH)	1	
	T6-6-10444	Motor (M3)(For 380V, 3PH)	1	
	T6-6-10441	Motor (M1)(For 415V, 3PH)	1	
40	T6-6-30200	Earth Plate (3P)(Only CE)	1	
41	T5-4-10310	Earth Plate (5P)(Only CE)	1	
42	TF-024	Transformer Cover	1	
44	T6-6-10540	Bracket (Only M2 Fan, 1PH)	1	
45	T6-6-10550	Fan (For M1/M2 Motor, 110V, 1PH)	2	
	T6-6-10551	Fan (For M1/M2 Motor, 220V/230V/ 240V, 1PH)	2	
46	T6-6-10560	Bracket (Only M1 Fan, 1PH)	1	
47	LA-20140	Label	1	
49	T7-5-20130	Micro Switch (Option)	1	
50	T7-6-40001	Pedal Control Set (Option)	1	
51	T6-6-11000	Pedal Control Set	1	
52	HBS0625	HBS, M6x25	2	
53	HBS0510	HBS, M5x10	4	
54	HBS0512	HBS, M5x12 (Only CE)	1	
55	PMS0410	PMS, M4x10	2	
56	HSS0610G	HSS, M6x10 (G)	4	
57	FMS0435S	FMS, M4x35 (SUS)	2	
58	HBS0620	HBS, M6x20	10	
59	TMS0308	TMS, M3x8	4	
60	TMS0508	TMS, M5x8	6	
61	TMS0408	TMS, M4x8	18	

REF. NO.	PART NO.	DESCRIPTION	Q'TY	REMARKS
62	TMS0408S	TMS, M4x8 (Stainless Steel Model)	8	
64	PMS0425	PMS, M4x25	6	
65	PMS0315	PMS, M3x15	2	
66	HN06	HN, M6	12	
67	HN04	HN, M4	8	
68	HN03	HN, M3	2	
69	PW06D	PW, M6 (D)(For 1PH)	2	
70	PW06C	PW, M6 (C)(For 1PH)	22	
		PW, M6 (C)(For 3PH)	24	
71	TF-006	Micro Switch (Option)	1	
72	PW05	PW, M5	4	
73	PW04	PW, M4	6	
74	SW05	SW, M5	3	
75	SW06	SW, M6	12	
76	SW04	SW, M4	4	
77	T6-6-10171	Heater Transformer Ass'y	1	
	T6-6-10172	Heater Transformer Ass'y (Only 110V)	1	
78	SW03	SW, M3	2	
79	T6-6-10895	Motor starting capacitor (For M1/M2, 220V, 1PH)	2	
	T6-6-10893	Motor starting capacitor (For M1/M2, 110V, 1PH)	2	
	T6-6-10894	Motor starting capacitor (For M1/M2, 240V, 1PH)	2	
81	T6-6-10915	Motor starting capacitor (For M3, 220V, 1PH)	1	
	T6-6-10912	Motor starting capacitor (For M3, 110V, 1PH)	1	
	T6-6-10914	Motor starting capacitor (For M3, 240V, 1PH)	1	

6-1**ELECTRIC CONTROL GROUP****T6-6-10035****T6-6-10036**

REF. NO.	PART NO.	DESCRIPTION	Q'TY	REMARKS
85	T6-6-10950	Reset Switch (For S.F.S.)(Option)	1	
86	T6-6-10960	Relay (For S.F.S.)(Option)	1	
88	T6-6-10980	Cable Gland (PG11)	3	
89	T6-6-30310	Lamp	1	
91	FTP0416A	FTP, 4x16 (A)	1	
92	KUC-1.5	Cable Clamp	1	
96	PMS0408	PMS, M4x8	2	

6-2

**ELECTRIC CONTROL GROUP T6-6-30025
T6-6-30026**

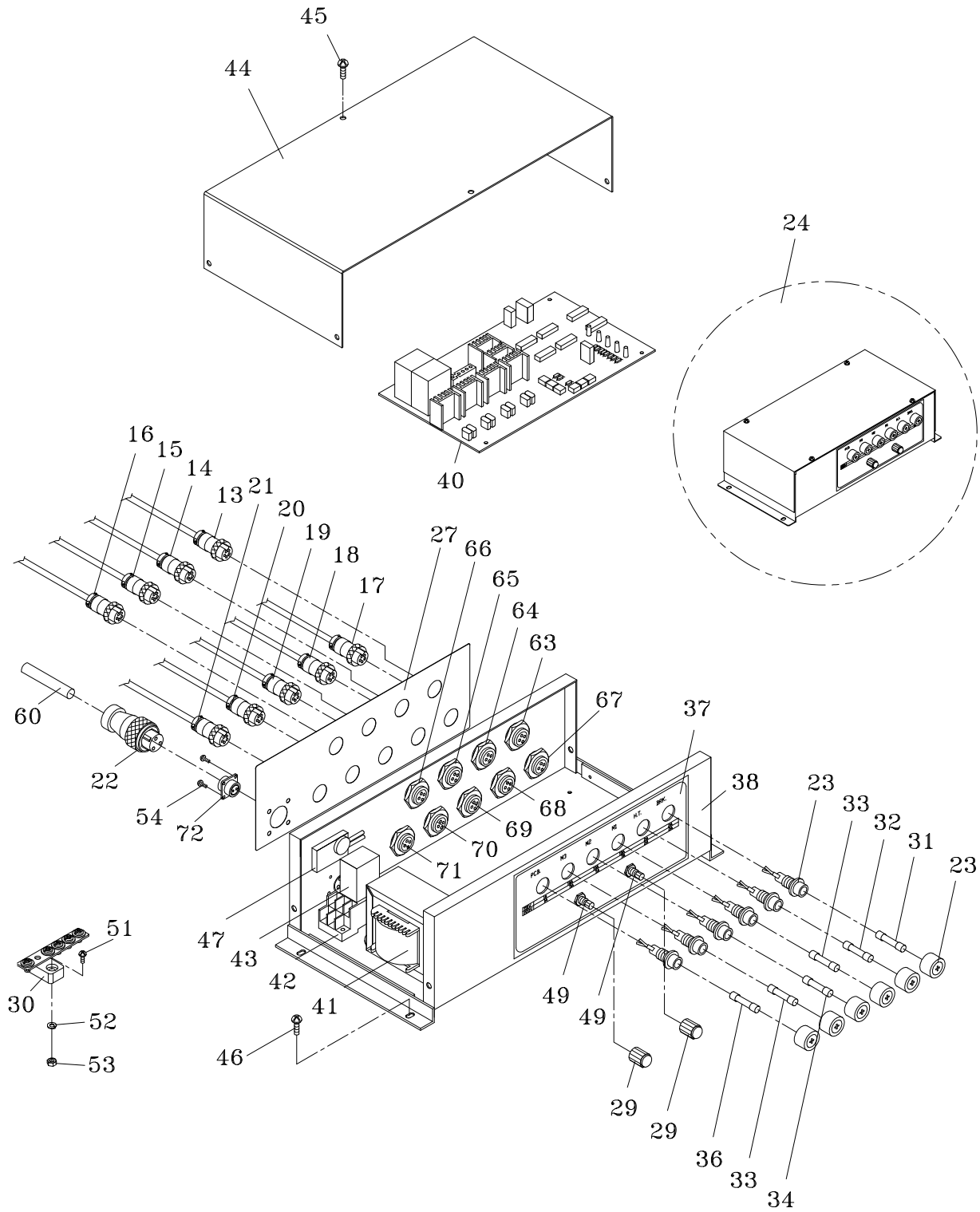

TP-6000-1/TP-6000CE1

REF. NO.	PART NO.	DESCRIPTION	Q'TY	REMARKS
	T6-6-30025	Electric Control Group (For TP-6000-1, 220V/230V/240V)	1	
	T6-6-30026	Electric Control Group (For TP-6000-1, 110V)	1	
	T6-6-40034	Electric Control Group (For TP-6000CE1, 220V/230V/240V)	1	
	T6-6-40035	Electric Control Group (For TP-6000CE1, 110V)	1	
13	T6-6-30013	Connector (LS1/LS2/LS3)	1	
14	T6-6-30014	Connector (Switch 2)	1	
15	T6-6-30015	Connector (Switch 1)	1	
16	T6-6-30016	Connector (LS4/Foot)	1	
17	T6-6-30017	Connector (Braker)	1	
18	T6-6-30018	Connector (Heater)	1	
19	T6-6-30019	Connector (M1)	1	
20	T6-6-30020	Connector (M2)	1	
21	T6-6-30021	Connector (M3)	1	
22	T6-6-10353	Connector (Plug)(Power)	1	
23	T5-4-10160	Fuse Holder	6	
24	T6-6-30140	Electric Control Group (For TP-6000-1, 220V/230V/240V)(Without Wire Ass'y)	1	
	T6-6-30141	Electric Control Group (For TP-6000-1, 110V)(Without Wire Ass'y)	1	
	T6-6-40054	Electric Control Group (For TP-6000CE1, 220V/230V/240V) (Without Wire Ass'y)	1	
	T6-6-40055	Electric Control Group (For TP- 6000CE1, 110V)(Without Wire Ass'y)	1	
27	LA-20071	Label	1	
29	T6-6-30029	Knob	2	
30	T5-4-10310	Earth Plate (5P)(Only CE)	1	
31	T6-6-30031	Fuse (2A)(For 220V/230V/240V)	1	
32	T6-6-30032	Fuse (3A)(For 220V/230V/240V)	1	
	T6-6-30134	Fuse (6A)(For 110V)	1	
33	T6-6-30033	Fuse (5A)(For 220V/230V/240V)	2	
	T6-6-30133	Fuse (10A)(For 110V)	2	

REF. NO.	PART NO.	DESCRIPTION	Q'TY	REMARKS
34	T6-6-30034	Fuse (7A)(For 220V/230V/240V)	1	
	T6-6-30133	Fuse (10A)(For 110V)	1	
36	T6-6-30036	Fuse (1A)	1	
37	LA-20070	Label	1	
38	T6-6-30038	Electric Box	1	
40	T6-6-30040	P.C. Board	1	
41	T6-6-30041	Transformer	1	
42	T6-6-30042	Relay Socket (Only Non CE)	1	
43	T6-6-30043	Relay (Only Non CE)	1	
44	T6-6-30044	Cover	1	
45	PMS0306	PMS, M3x6	8	
46	TMS0508	TMS, M5x8	4	
47	T6-6-30047	EMI Filter	1	
49	T6-6-30049	Variable Resistor (1M)	2	
51	TMS0412	TMS, M4x12 (Only CE)	1	
52	SW04	SW, M4 (Only CE)	1	
53	HN04	HN, M4 (Only CE)	1	
54	TMS0308	TMS, M3x8	4	
60	T6-6-30350	Power Cable (Only CE)	1	
63	T6-6-30313	Connector (Socket)(LS1/LS2/LS3)	1	
64	T6-6-30314	Connector (Socket)(Switch 2)	1	
65	T6-6-30315	Connector (Socket)(Switch 1)	1	
66	T6-6-30316	Connector (Socket)(LS4/Foot)	1	
67	T6-6-30317	Connector (Socket)(Braker)	1	
68	T6-6-30318	Connector (Socket)(Heater)	1	
69	T6-6-30319	Connector (Socket)(M1)	1	
70	T6-6-30320	Connector (Socket)(M2)	1	
71	T6-6-30321	Connector (Socket)(M3)	1	
72	T6-6-10352	Connector (Socket)(Power)	1	

6-2

ELECTRIC CONTROL GROUP T6-6-50001 T6-6-50002 (1 OF 2)

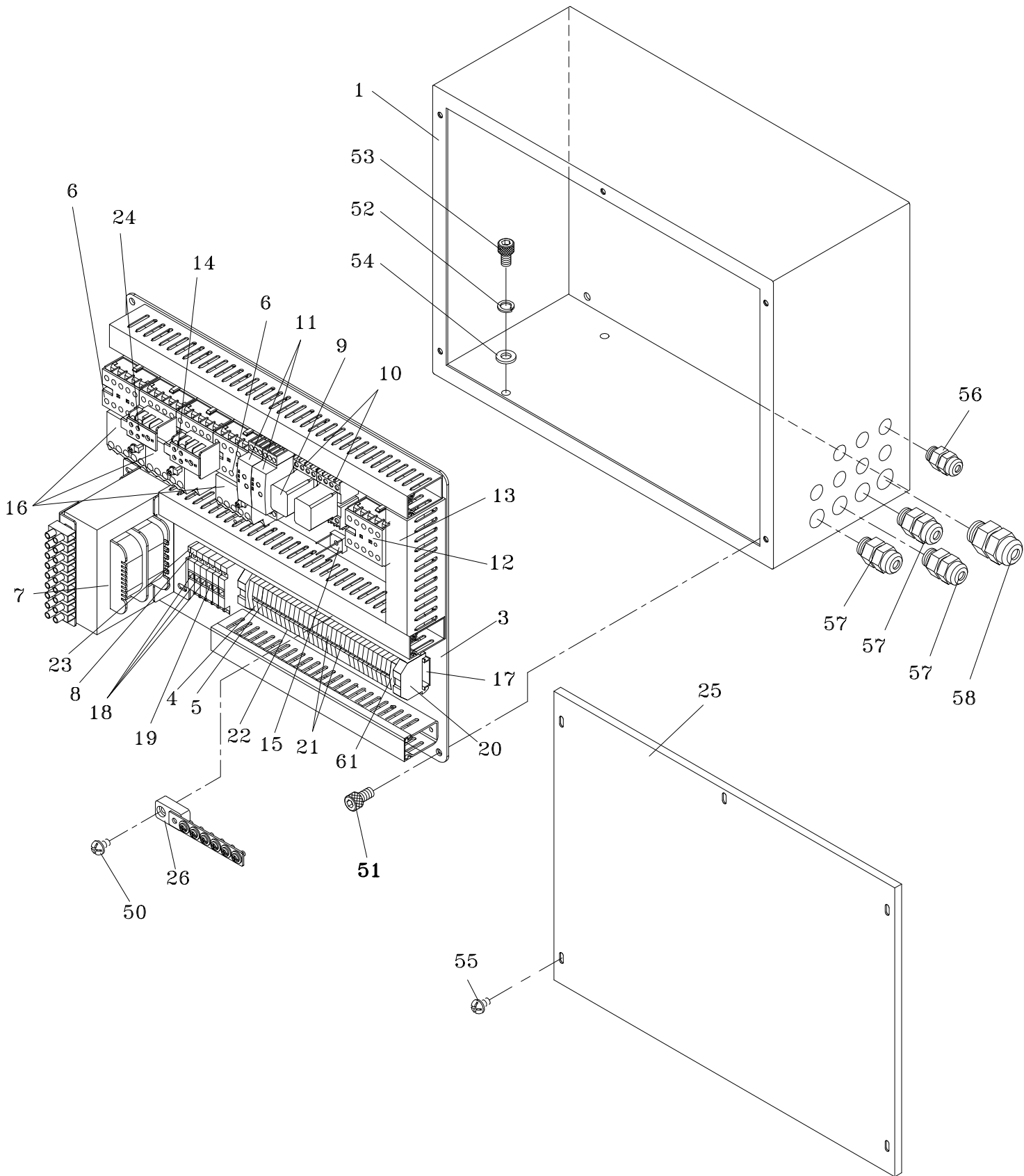

TP-6000-3/TP-6000CE3

REF. NO.	PART NO.	DESCRIPTION	Q'TY	REMARKS
	T6-6-50001	Electric Control Group (For TP-6000-3)	1	
	T6-6-50002	Electric Control Group (For TP-6000CE3)	1	
1	T6-6-50110	Electric Box	1	
3	T6-6-50130	Panel	1	
4	T6-6-50140	Terminal (Ground)	5	
5	T6-6-50150	Terminal (Control) (Single in, single out)	22	
6	T6-6-50161	Magnetic Switch	4	
7	T6-6-50170	Transformer (For 220V/ 380V/ 415V/24V)	1	
8	T6-6-50180	Fuse Holder (For Non CE) Fuse Holder (For CE)	5 6	
9	T6-6-50190	Relay	2	
10	T6-6-50200	Relay Socket	2	
11	T6-6-50211	Timer	2	
12	T6-6-50220	Magnetic Switch (Only Non CE)	1	
13	T6-6-50230	Wire Duct 25x45	1set	
14	T6-6-50241	ADD-ON Contact (M2F)(2a)	1	
15	T6-6-50250	Rectifier	1	
16	T6-6-50261	Over Load Relay	3	
17	T6-6-50270	Terminal Guide	1	
18	T6-6-50280	Fuse (5A)	3	
19	T6-6-50290	Fuse (2A)	2	
20	T6-6-50300	End Stop	2	
21	T6-6-50310	Terminal (Control)(Two in, two out)	2	
22	T6-6-50320	Group Marker Carrier	4	
23	T6-6-50330	End Plate (Fuse)	1	
24	T6-6-50341	ADD-ON Contact (M2R)(1a1b)	1	
25	T6-6-50350	Cover	1	
26	T6-6-10250	Earth Plate (6P)(Only CE)	1	

REF. NO.	PART NO.	DESCRIPTION	Q'TY	REMARKS
50	TMS0512	TMS, M5x12 (Only CE)	1	
51	HBS0616	HBS, M6x16	4	
52	SW05	SW, M5	3	
53	HBS0510	HBS, M5x10	3	
54	PW05	PW, M5	3	
55	TMS0508	TMS, M5x8	5	
56	T5-2-10500	Cable Gland (PG9)	7	
57	T6-6-10980	Cable Gland (PG11)	3	
58	T6-6-10340	Cable Gland (PG13.5)	1	
59	SW06	SW, M6	4	
60	HN06	HN, M6	4	
61	T6-6-50410	End Plate (Control)	1	

6-2

ELECTRIC CONTROL GROUP T6-6-50001 T6-6-50002 (2 OF 2)

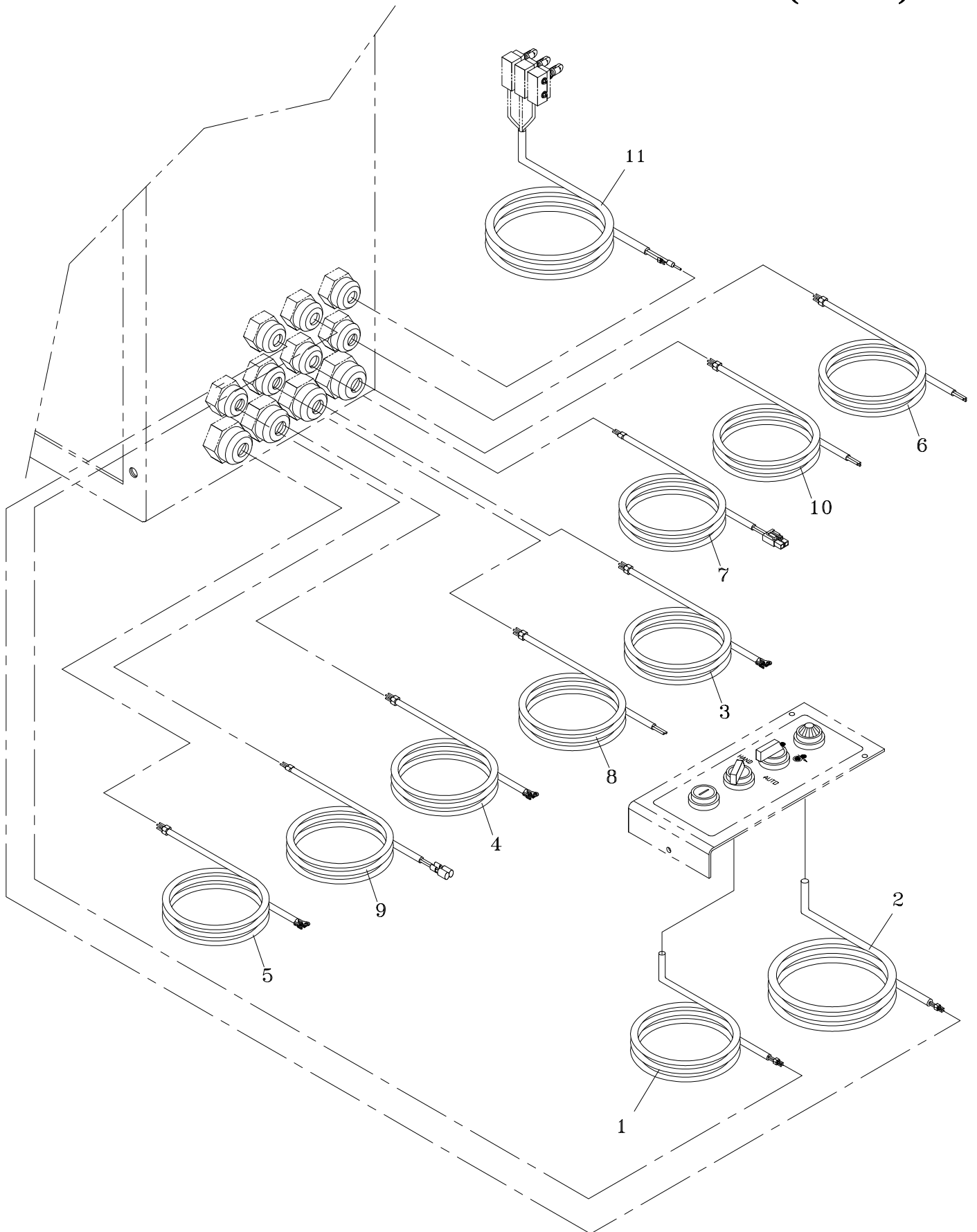

REF. NO.	PART NO.	DESCRIPTION	Q'TY	REMARKS
1	T6-6-50470	Wire Ass'y (Control Panel)(For CE)	1	
	T6-6-50480	Wire Ass'y (Control Panel) (For Non CE)	1	
2	T6-6-50490	Wire Ass'y (Control Panel) (Only Non CE)	1	
3	T6-6-50500	Motor Cable (M1)	1	
4	T6-6-50510	Motor Cable (M2)	1	
5	T6-6-50520	Motor Cable (M3)	1	
6	T6-6-50530	Wire Ass'y (H.T)	1	
7	T6-6-50540	Wire Ass'y (BRK)	1	
8	T6-6-50550	Wire Ass'y (LS4)	1	
9	T6-6-50560	Wire Ass'y (Foot)(Only Non CE)	1	
10	T6-6-50570	Wire Ass'y (Power)	1	
11	T6-6-50580	Wire Ass'y (LS1/LS2/LS3)	1	



Мир Упаковки-продажа упаковочного
оборудования и материалов
Сервис ремонт запасные части
+7 (495) 971-53-02
www.world-packing.su
info@world-packing.su